

conscriptor.net

"TRADER" SERVICE SHEET

864

E.M.I. CORD DRIVES

Replacement Instructions for Most Popular Early Tuning Drive Systems

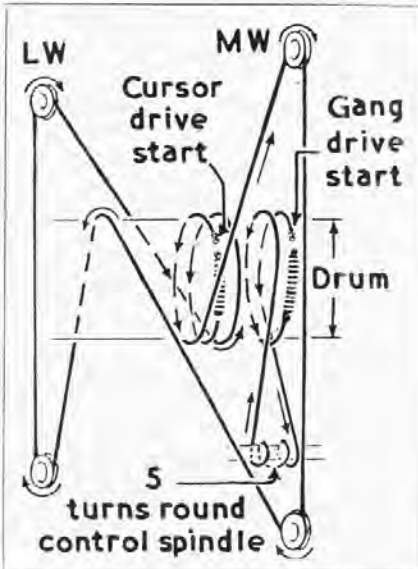

Diagram showing the rather complicated course followed by the drive cords in the 442 series. The turns on the drum are widely spaced here for clarity, but the finished job should look like the small sketch of the drum opposite.

Gang Drive. Approximate length 30in. Turn gang to maximum and control spindle clockwise to its stop. The anchor plates should now be at the top of the drum. If they are not, slacken the hexagon screw and adjust the drum. The

THE following drive cord replacement instructions cover the most frequently encountered systems in the early E.M.I. receivers. In each case the cord recommended is superior flax fishing line having a breaking strain of 42lb, which can be obtained from E.M.I. Sales & Service, Ltd., Sheraton Works,

Wadsworth Road, Greenford, Middlesex. The cord should be rubbed well with hard wax to make it grip firmly.

It is usually necessary where two cords are involved to fit them in the same order as we describe them. If the one taking second place is intact, it should be removed until the other has been completed.

H.M.V. 438, 442, 443
Marconiphone 296, 298

cheese-headed screw **A** should be in the centre of its radial slot. Splice "S" hook to one end of cord, hook it to the rear left-hand anchor, take it anti-clockwise to the control spindle as shown in the sketch, making five turns clockwise round the spindle and one turn anti-clockwise round the drum. Then tie off to spring so as to open coils slightly. Take care that the cord lies in the grooves provided on the drum, as shown in the separate sketch.

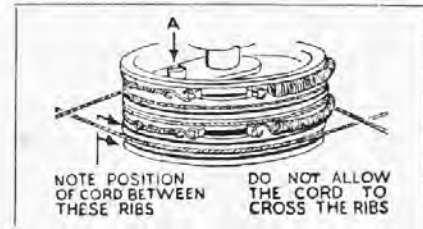

How the drum should appear when the cords have been run correctly. Screw **A** is on the rear of the drum.

Cursor Drive. Approximate length 60in. Splice "S" hook to one end of cord, remove the cursor guide bars, and thread free end of cord through holes in cursor carriages. Check that cursors are correct way round, then adjust them so that the distance between the end of the hook and the rear hole in the first cursor is exactly 15in, and the distance between the adjacent holes in the two cursors is exactly 18in, leaving about 18in of cord free. Turn gang to maximum, hook cord to front left-hand anchor and pass cord anti-clockwise half turn round drum, then up over "MW" pulley and so on, following the sketch, finish-

ing up by passing over "LW" pulley and making about 1½ turns anti-clockwise round the drum to finish by tying off to tension spring as before. Finally, check that cord runs in correct grooves as illustrated in the separate drum sketch and replace pointer guide bars, threading them through the cursors and securing at top and bottom.

Approximate length of cord 52in. Its specification number is 8515.

Turn gang to minimum and turn control spindle anti-clockwise to its stop. Tie the two tension springs to the ends of the cord so that they are exactly 49in apart.

Pass one end through upper hole in front plate and hook spring to stud 2 on drive drum.

Take free cord round pulley and 1½ turns anti-clockwise round left-hand pointer drum, second circuit going behind first turn and looping through slots, as indicated in sketch.

Follow arrows in sketch, making three turns round threaded part of control spindle, as far back as possible, and hold cord taut with left hand at point **A**.

Take second spring through lower hole in front plate, and round drive drum to stud 2 as shown, pass cord over pulleys 3 and 4, down through right-hand pointer-drum slots, which should be where they are indicated, and wind two complete turns anti-clockwise on the drum.

Tension cord by straining it over pulley 5. If further tension is needed, pulley 4 can be adjusted. Adjust calibration at about 3000 m and 1,400 m.

Note.—If the stops on the tuning control spindle prevent the gang vanes from closing fully, the drive drum should be adjusted on the gang spindle before adjusting the calibration.

H.M.V. 470, 523, 524
Marconiphone 290, 291

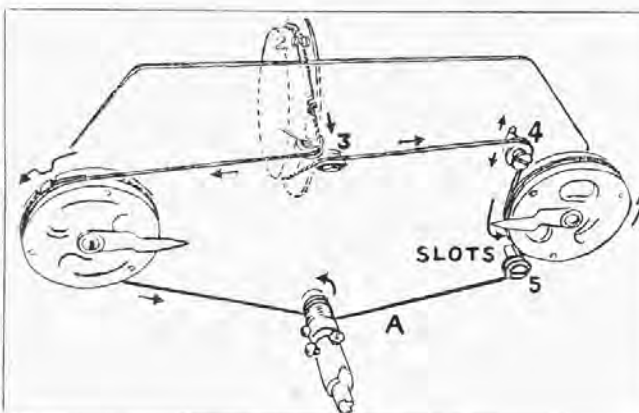

Sketch showing the course taken by the drive cord in the 290 series. The cord is looped into slots on the scale drums to obtain a firm grip. Note that when completed the two scales revolve in opposite directions.

conscriptor.net

H.M.V. 440, 441, 512, 540, 541, 542, 570, 570A
Marconiphone 262, 264, 272, 274, 286, 287
288, 289, 297

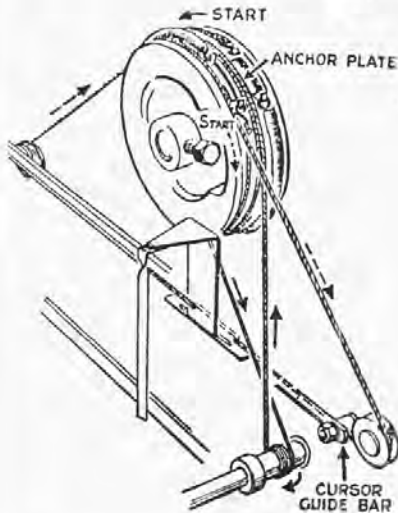

Gang Drive. Approximate length 30 inches. Remove scale from its frame, turn gang to maximum, and turn control spindle clockwise to its stop.

The anchor plates should now be at the top of the drum. If they are not, slacken the hexagon screw and adjust the drum. See that the cheese-head screw (at rear) is in the centre of its radial slot.

Splice "S" hook to one end of cord, slip it

over the rear left-hand anchor-point of drum and bring cord once round wide rear channel anti-clockwise, down through aperture in chassis, over the right-hand side of the control spindle;

make four complete turns round the undercut portion of the spindle, keeping it at stop and the gang at maximum;

come round as for a fifth turn, but pass cord through aperture in chassis, and anti-clockwise along centre (narrow) groove in gang drum for one turn, and splice end of cord to tension spring so that its coils open slightly when hooked to rear right-hand anchor point.

The cord will cross from centre to rear groove before completing one revolution of the drum.

Cursor Drive. Approximate length 36 inches.

Remove scale, cursor guide bar and cursor.

Splice "S" hook to one end of cord, thread other end through holes in cursor carriage so that hook end is on the right and exactly 1 1/4 ins. from the nearest hole. Then replace cursor on guide bar, and replace guide bar.

Turn gang to maximum, slide cursor fully right, hook cord to front right-hand anchor and pass cord once clockwise round front channel of drum and over right-hand pulley.

Take free end of cord round left-hand pulley and clockwise along centre (narrow) channel of drum a single turn, splicing on to tension spring as in the case of gang drive.

The cord will cross from centre to front groove before completing one revolution of drum.

Models 512 & 274

Gang Drive. Exactly as for 262.

Pointer Drive.—Approximate length 30 inches.

Except for the length and the use of two pointers, the procedure is the same as for 262 series.

Cord is first threaded through holes in pointer carriages (as in 442), and distance between "S" hook and first hole is adjusted to exactly 1 1/4 inches.

H.M.V. 436
Marconiphone 253, 254
Columbia 355, 620

Gang Drive, Both Models. Approximate length 30 inches. Specification number is 8515.

Turn gang and control spindle both to their stops in an anti-clockwise direction. Tie a small loop at one end of cord, slip it over right-hand anchor 2, and take the cord down to the control spindle as shown in sketch, making 5 complete turns anti-clockwise, going backwards.

Take cord up, and make one turn clockwise round gang drum, and tie off to tension spring whose coils should open slightly when hooked to left-hand anchor 2. Check that cord is not chafed by contact with chassis.

Pointer Drive, Model 253. Approximate length 30 inches.

Splice an "S" hook on one end of cord, hook it to the pointer 5 and take cord round pulley 6, then make one complete turn round smaller (pointer) drive drum as shown.

Finish off round pulley 7 by tying spring to free end so as to open coils when hooked to pointer. Adjust pointer by slipping cord round drum.

Model 254. The pattern is the same as for 253, but the drum is same size as gang drive drum, and has the same kind of double anchor plate; it also starts in the same position as the gang drive and goes in same direction, but the pointer slides on a carriage.

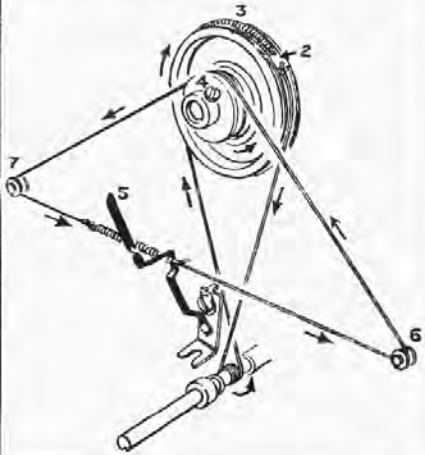

Marconiphone 256, 258, 276

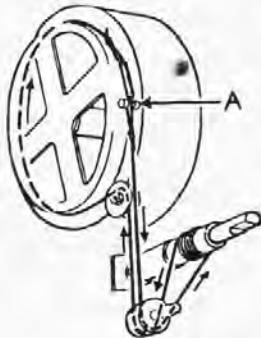

Approximate length of cord 30 inches.

Remove the tone control as far as the wiring will permit, turn the gang to minimum and turn the control spindle anti-clockwise to its stop.

A stiff piece of wire with a hooked end will be found helpful in manipulating the cord.

Fold back about an inch at one end of cord, tie it to form a loop, hook it over the anchor stud A, take cord downwards and follow the course shown in the sketch, making six turns round the control spindle.

Pull cord tight, then tie off to one end of tension spring so that spring coils open slightly when its other end is hooked to anchor stud A.

H.M.V. 580 & Marconiphone 292

To replace either cord, the chassis must be removed from the cabinet.

Indicator Drive. Approximate length 30 in.

Tie a loop about 3 in from one end, slip it through slot in pulley C and over stud K. Take the longer length one turn round C, then one turn round pulley D and loop it over stud L.

Tie the two free ends together and strain cord taut over jockey wheel M.

Gang Drive. Approximate length 56 in.

Thread cursor carriage with cord, using holes

adjacent to cursor side, and slide carriage to centre of cord.

Assemble carriage assembly on guide rod, set cursor to 500 m, and turn gang to maximum.

Adjust drum so that slot E is on right-hand side when chassis is viewed from front, when drum (which is fixed by screws H, J) will be against its stop.

Take the two lengths of free cord and pass them round their respective pulleys and the drum to slot E.

Pass them into drum through E, thread them through hole in flat spring G, and tie off so as to strain G when it is forced over studs F, F.

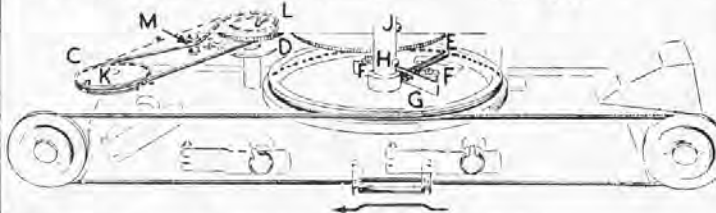

The shorter cord in the 580 and 292 drives the waveband indicator.