

conscriptor.net

FOLDER 7
SET 421

PHOTOFACT* Folder



GARRARD MODELS
RC 120/Mk. II, RC 121/Mk. II

GARRARD MODELS
RC 120/Mk. II, RC 121/Mk. II

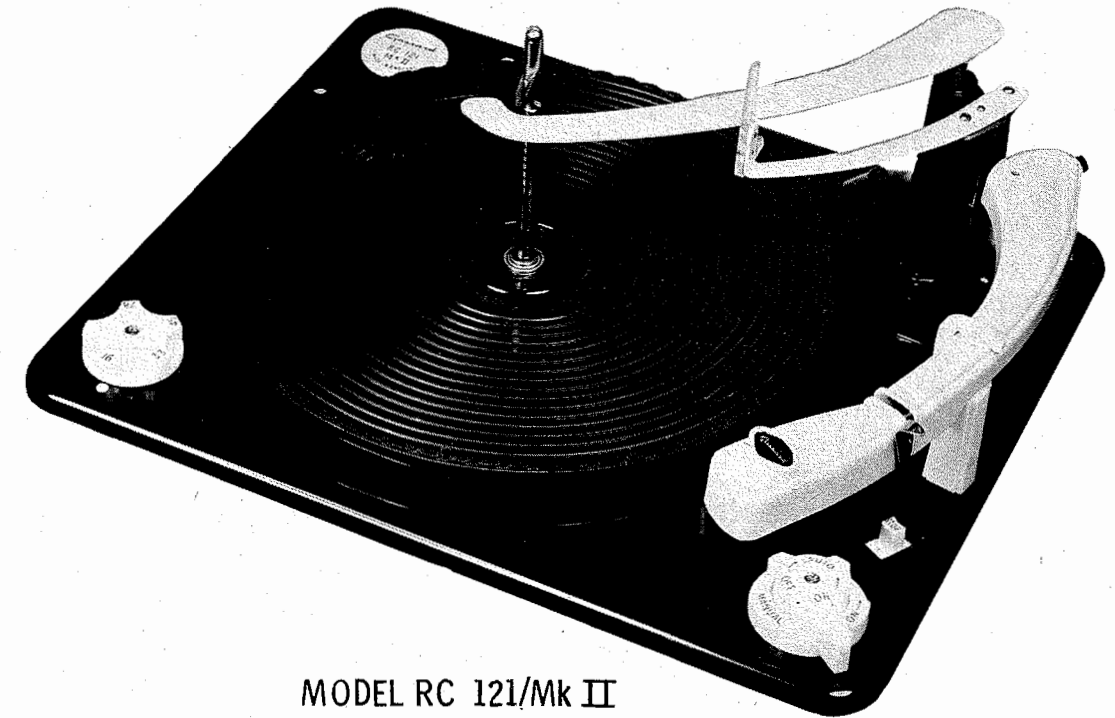

MODEL RC 121/Mk II

GENERAL INFORMATION

Garrard Models RC 120/ Mk. II and RC 121/ Mk. II record changers play four speeds--78, 45, 33 1/3, and 16 2/3 rpm.

The Model RC 120/ Mk. II has a one-piece, die-cast aluminum pickup arm, while the Model RC 121/ Mk. II has a plug-in pickup head. Except for this one difference, both models are exactly alike, and any reference to one model also applies to the other, unless otherwise stated.

Records of the same speed can be played at the same load if the smaller records are placed above the larger ones. Ten 45-rpm records, having the large center hole, may be played by using the Garrard large record spindle Type LRS 4, or center hole clip-in adaptors may be used.

Records may be rejected, played manually, or the changer may be stopped and restarted without rejecting the record being played.

Manufactured by:

The Garrard Engineering and Manufacturing Company, Limited
Newcastle Street
Swindon, Wilts., England

Distributed in the United States by:

Garrard Sales Corporation
80 Shore Road
Port Washington, New York

GARRARD MODELS
RC 120/Mk. II, RC 121/Mk. II

SET 421 FOLDER 7

This material compiled and published by

HOWARD W. SAMS & CO., INC., INDIANAPOLIS, INDIANA
C374

Copyright 1958 • All Rights Reserved

DATE 11-58

SET 421 FOLDER 7

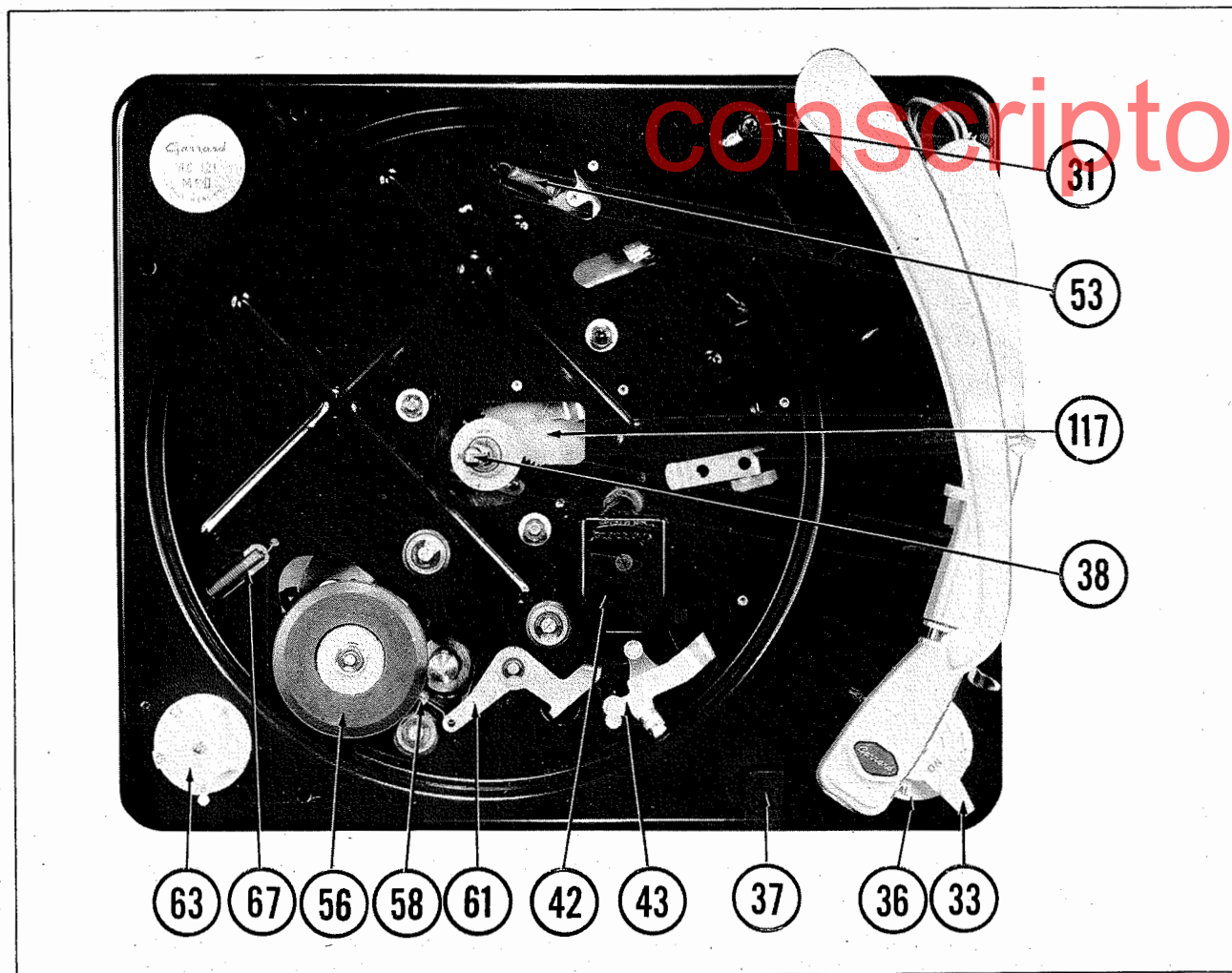

FIG. 1 CHANGER MECHANISM WITH TURNTABLE REMOVED

OPERATING INSTRUCTIONS

To Operate The Garrard Changer:

1. Release pickup arm latch (9).
2. Set stylus for type of record to be played.
3. Set Speed Control knob.
4. Set records on record spindle (38) and move overarm (1) inward.
5. Switch on mechanism, using Auto. Control knob for automatic operation or Manual Control knob for manual operation.

To Reject

To reject a record, move Auto. Control knob to On. Pickup arm (16) will lift from the record being played and return to its rest, and the next record will drop. If no more records are on record spindle (38), the changer switches off automatically.

To Stop

To stop the changer without rejecting the record being played, move the Stop lever knob forward. This action switches off the changer, but leaves the pickup on the record. Switch on the mechanism with the lower Manual Control knob. The changer will continue to play the same record from the same point where it stopped.

Manual Operation

To play a record manually, move overarm (1) outward, place record on record spindle (38), threading the record over the offset step on the spindle. Turn the Manual Control knob to On and place pickup on the record. The automatic trip will return the pickup to its rest when the record is finished.

To Switch Off

To switch off the changer while leaving the pickup on its rest, move the Auto. Control knob to Off. The pickup will lift and return to its rest, and the changer will switch off.

MECHANICAL PARTS LIST (Con't)

Ref. No.	Part No.	Description
101	A. 40512	Washer (Large)
102	A. 40535	Washer (Small)
103	A. 41723	Spring Clip Retaining Stop Cam Lever
104	B. 54725	Stop Catch Lever
105	A. 41723	Spring Clip Retaining Fixing Plate
106	A. 41503	Spring For Stop Catch Lever
107	A. 54698	Knock Off Lever With Bush And Pin
108	A. 54662	Stop Link
109	A. 40695	Washer For Stop Link
110	A. 41723	Spring Clip For Stop Link
111	A. 54659	Auto Stop Link With Pins
112	A. 40695	Washer (Thick)
113	A. 40836	Washer (Thin)
114	A. 41723	Spring Clip Retaining Auto Stop Link
115	A. 41801	Spring For Cam Selector Lever
116	B. 54625	Cam Selector Lever
117	B. 54642	Cam Assembly Complete With Cams
118	A. 54786	Spacer
119	A. 40695	Washer
120	A. 41723	Spring Clip Retaining Cam Selector Lever
121	A. 54630	Bridge With Turntable Spindle Housing And Pickup Connector
122	A. 54656	Release Lever With Spring Blade And Pin
123	A. 40695	Washer
124	A. 41696	Spring Clip Retaining Release Lever
125	A. 41824	Release Spring
126	A. 54645	Friction Lever
127	A. 55530	Trip Pawl Unit
128	A. 55507	Brass Collar

Ref. No.	Part No.	Description
129	A. 43803	Spring Clip
130	A. 41806	Friction Spring
131	A. 54709	Speed Change Spindle
132	A. 46680	Cross Pin For Speed Change Spindle
133	A. 40535	Washer (Thin)
134	B. 54619	Index Lever
135	A. 40836	Washer (Thick)
136	A. 41723	Spring Clip Retaining Index Lever
137	A. 54385	Cam For Speed Change
138		Pin And Roller
139	A. 41788	Spring Clip Retaining Cam
140	A. 54386	Support Lever With Pin And Roller (Large Casting)
141	A. 41786	Lifting Spring For Speed Change
142	A. 40817	Cupped Washer
143	A. 43807	Spring Clip
144	A. 54701	Motor Mounting Plate With Pillar
145	A. 40118	Screw Fixing Motor
146	B. 55150	Dual Range Motor Complete
147	B. 54700	High Range Motor Complete
	A. 53350	Bobbins Complete (Dual Range Motor)
	A. 53259	Bobbin (Left) Complete (High Range Motor)
	A. 53260	Bobbin (Right) Complete (High Range Motor Only)
148	A. 53962	Motor Cover (Top) With Bearing
	B. 53963	Motor Cover (Bottom) With Bearing
	A. 43209	Thrust Ball For Bottom Motor Cover
149	A. 40698	Washer (2) Or Collar A. 55320
150		Cam For Record Spindle (Part Of Item 86)

MECHANICAL PARTS LIST

Ref. No.	Part No.	Description
1	B. 54846	Overarm With Spindle
2	A. 40353	Screw For Selector Arm (2)
3	A. 54733	Eccentric Adjustment Screw
4	A. 54692	Selector Arm
5	A. 54693	Record Cam
6	A. 44049	Fixing Screw (2)
7	A. 54626	P. U. Rest Complete. Comprising:
8	C. 54773	Pickup Rest Body
9	A. 54774	Latch Unit
10	A. 54716	Bracket
11	A. 41635	Spring
12	A. 41012	Nut
13	A. 40515	Washer
14	A. 42501	Spring Washer
15	A. 40155	Screw
16	B. 54720	RC. 120 Mk. II Pickup Arm Assy. Complete (Less Cartridge)
	B. 55130	RC. 121 Mk. II Pickup Arm Assy. Complete With Plug In Head (Less Cartridge)
17	A. 55246	MPM3 Plug In Pickup Head (Closed Front) Assembly Complete Less Cartridge
	A. 55249	MPM3 Plug In Pickup Head (Open Front) Assembly Complete Less Cartridge
18	A. 40483	Counterbalance Screw
19	A. 54734	Pivot Pin For P. U. Arm
20	A. 54572	Counterbalance Arm
21	A. 41805	Counterbalance Spring Model RC. 120 Mk. II
	A. 41821	Counterbalance Spring Model RC. 121 Mk. II
22	A. 41757	Locking Spring For Adj. Screw
23	A. 44043	Height Adjusting Screw
24	A. 43203	Steel Ball Model RC. 121 Mk. II
25	A. 40350	Screw Fixing Pivot Pin
26	A. 43348	Split Pin
27	A. 40511	Washer
28	A. 54676	Pickup Arm Pivot Bracket Complete With Spindle
29	A. 43204	Steel Balls
30	A. 44042	Fixing Screws For P. U. Base
31	C. 54667	P. U. Base Assembly Complete
32	A. 44039	Screw Fixing Control Knob
33	B. 54611	Auto Control Knob
34	A. 40830	Tab Washer For Auto Control Knob
35	A. 43807	Spring Clip Retaining Control Knob
36	B. 54609	Manual Control Knob
37	C. 54601	RC. 120 Mk. II Unit Plate Complete With Pivot Pins, Bushes For Control and Name Plate
	C. 55412	RC. 121 Mk. II Unit Plate Complete With Pivot Pins, Bushes For Controls and Name Plate
38	B. 54638	Record Spindle With Latches, Pawl And Fixed Spindle
39	A. 53176	Spring Clip Retaining Turntable
40	C. 54848	Turntable Cover
41	B. 53394	Turntable
42	B. 51322	Switch Block
43	B. 55519	Switch Lever With Felt Pad and Contact
44	A. 45064	Felt Pad For Switch Lever
45	A. 54815	Turntable Spindle With Striker

Ref. No.	Part No.	Description
46	A. 40804	Thrust Washer (Small Hole)
47	A. 43201	Ball Bearing
48	A. 51224	Ball Race Cage
49	A. 40713	Thrust Washer (Large Hole)
50	A. 40789	Plastic Washer
51	A. 41006	Nut
52	A. 40695	Washer
53	A. 41808	Spring For Cam Selector Lever
54	A. 41723	Spring Clip Retaining Intermediate Wheel
55	A. 40774	Presspahn Washer For Intermediate Wheel
56	B. 53883	Intermediate Wheel With Bearing
57	A. 54984	Support Bracket With Pivot Pin For Intermediate Wheel (Small Casting)
58	A. 41792	Tension Spring
59	A. 41723	Spring Clip Retaining Switch Lever
60	A. 40695	Washer
61	A. 54616	Tension Lever
62	A. 44039	Screw Fixing Speed Control Knob
63	B. 54613	Speed Control Knob
64	A. 40830	Tab Washer For Speed Control Knob
65	A. 43807	Spring Clip
66	A. 40536	Steel Washer
67	A. 41661	Spring For Index Lever
68	A. 43800	Circlip Retaining Motor (3)
69	A. 40828	Washer (3)
70	A. 43109	Grommet Fixing Motor
71	A. 55522	Manual Control Lever
72	A. 54621	Return Lever
73	A. 54617	Control Lever With Pin And Spindle
74	A. 55408	Stop Lever Knob
75	A. 54620	Control Link
76	A. 54816	Pickup Base With Pickup Cam Spindle Guide Bracket, Inter Selector Lever And Spring Pin
77	A. 41506	Spring For Inter Selector Spindle
78	A. 54682	Pickup Lever With Lifting Pin And Spring Clips
79	A. 41006	Nut
80	A. 44041	Screw Fixing Pickup Lever
81	A. 41796	Return Spring
82	A. 54687	Lifting Spindle With Plate And Bush
83	A. 41833	Spring
84	A. 43803	Spring Clips (2)
85	A. 54663	Cam Link With Roller
86	A. 54710	Pickup Cam With Roller Pin, Roller And Spring Clip
87	A. 54714	Roller For Pickup Cam
88	A. 41723	Spring Clip Retaining Roller
89	A. 41788	Spring Clip Retaining Pickup Cam
90	A. 40503	Washer
91	A. 41834	Spring For Pickup Cam
92	A. 54694	Selector Lever With Selector Tension Lever, Bush And Spring
93	A. 40488	Screw Fixing Selector Lever
94	A. 41804	Spring
95	A. 41506	Spring For Control Link
96	A. 41631	Spring For Stop Cam Lever
97	A. 40695	Washer
98	A. 41723	Spring Clip Retaining Switch Lever
99	A. 54726	Fixing Plate For Stop Catch Lever
100	B. 54624	Stop Cam Lever

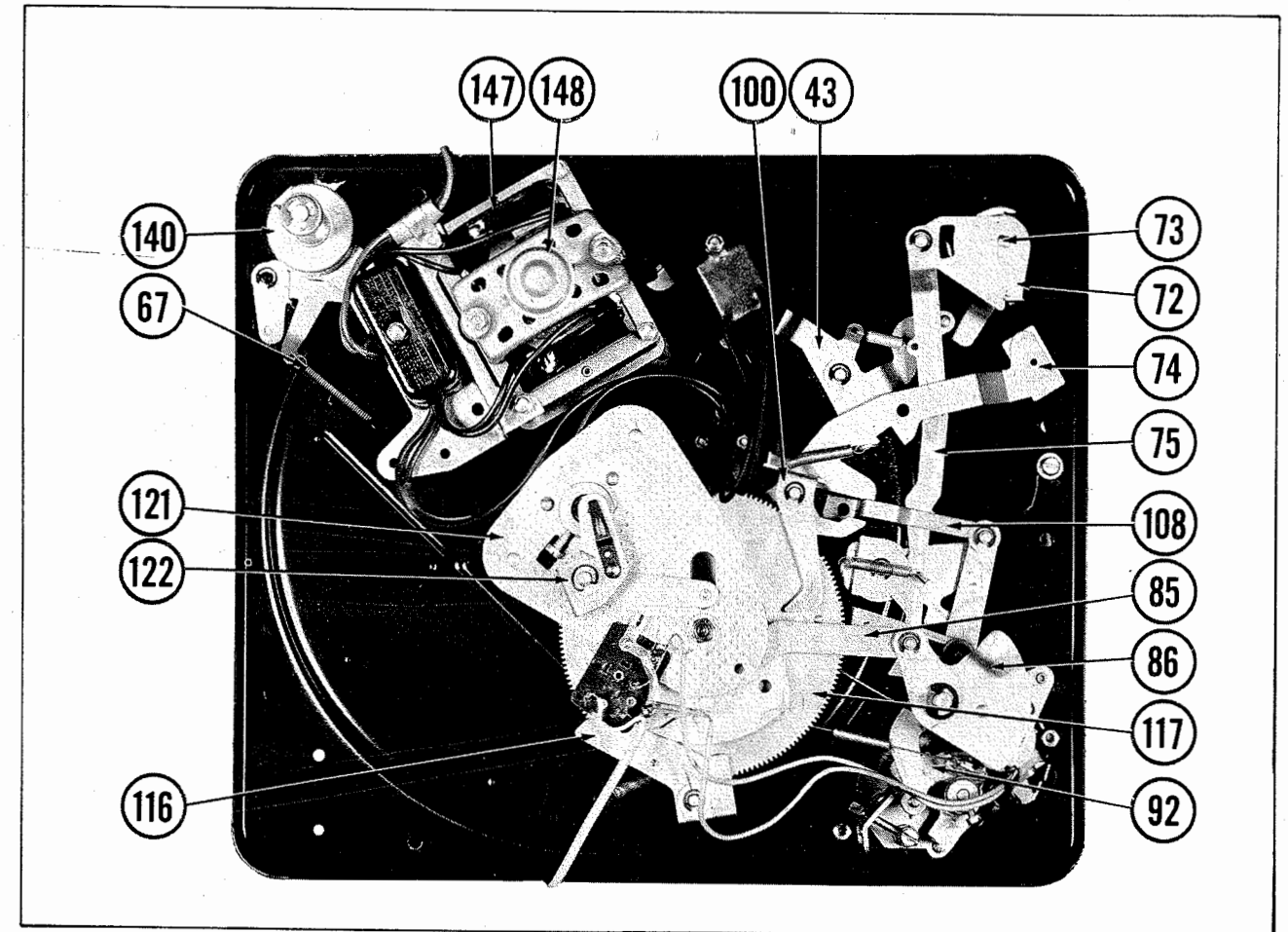

FIG. 2 BOTTOM VIEW OF CHANGER MECHANISM

To Play 45-rpm Records

To play 7", 45-rpm records with a 1 1/2" center hole, and using the large record spindle Type LRS 4:

1. With pickup arm (16) on its rest, place the LRS 4 spindle, with the arrow pointing to the front of the changer, over record spindle (38) and push down firmly.
2. Load any number of records up to 10 on the spindle and move overarm (1) inward, allowing it to rest on top of the spindle instead of on top of the records. This step is essential

to insure correct changer operation and record selection.

3. To remove records, wait until the changer has stopped automatically. Then swing overarm (1) outward. Remove the records from the spindle by placing the thumbs on the outer edge of the records.
4. Before removing the LRS 4 record spindle, make sure the changer is in its rest position, with overarm (1) moved to the right. Then lift off spindle.

LUBRICATION

Because the motor and intermediate wheel bearings are of the oil retaining type, they rarely need lubricating.

Should lubrication be necessary, hold the intermediate wheel out of the way and lubricate the top of the motor bearings with a drop of fine grade light machine oil. Remove all traces of surplus oil before

running the unit. The intermediate wheel rubber tire, motor pulley, and inside of the turntable rim must be kept free of oil or grease; otherwise, the drive will slip.

Occasionally a smear of light grease should be applied to all cam faces, and all lever pivots should be lightly lubricated.

GARRARD MODELS
RC 120/Mk. II, RC 121/Mk. II

FOLDER 7

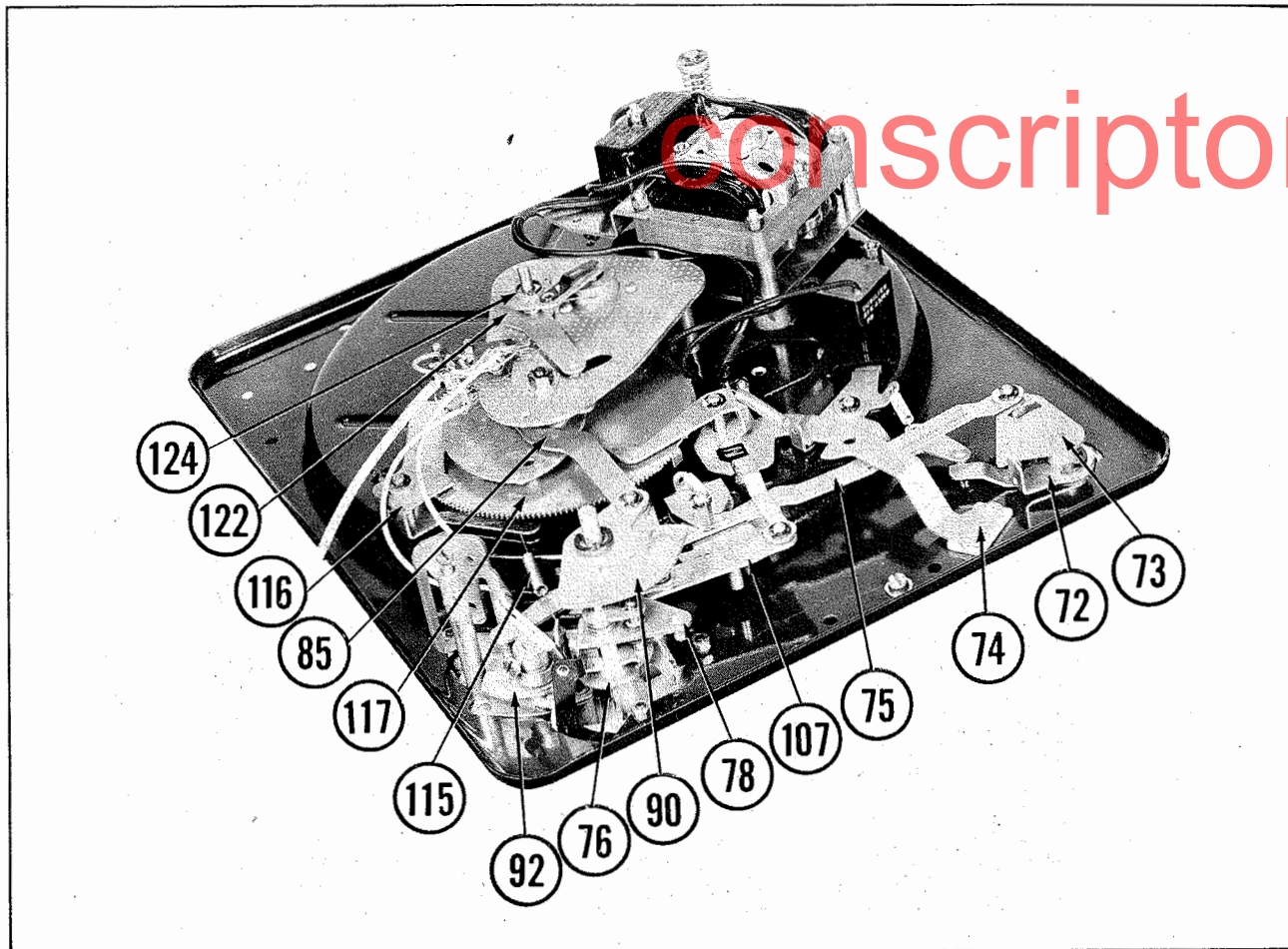

FIG. 3 TILTED BOTTOM VIEW OF CHANGER MECHANISM

CHANGE CYCLE

Observe the change cycle operation by manually rotating the turntable. The following action can then be readily followed and the function of each part easily understood.

The automatic trip mechanism operates on the velocity trip principle--the mechanism operates only when the inward motion of the pickup reaches the lead-out grooves at the end of the record. The trip is set to commence when the pickup reaches a radius of 2 5/8", and it should operate on an acceleration of not less than 3/32" with at least 1 1/2 revolutions of a record.

The trip mechanism is mounted on cam gear (117) and can be seen by removing the turntable when the changer is in its playing position. Trip pawl (127) is pivoted on cam gear (117) and is moved inward by the motion of the pickup arm through friction lever (126) toward turntable spindle (38). A projection on the turntable spindle (point "A" on Exploded View), called the striker, pushes trip pawl (127) back against the light friction of friction lever (126), trying to move it inward. This action occurs as long as the pickup is moving slowly, such as when in the playing grooves of a record. This action begins when the pickup reaches

a radius of 2 7/8" and continues until the inward motion of the pickup is accelerated. Trip pawl (127) is then pushed inward too far to be pushed back by the striker. The striker (point "A" on Exploded View) then positively engages trip pawl (127), pushing cam gear (117) so that the teeth of cam gear (117) engage those on the turntable.

As cam gear (117) begins rotating, the eccentric part of the cam gear contacts cam link (85) and moves it toward the turntable spindle. Cam link (85) and pickup cam (86) are connected and move in unison. As pickup cam (86) begins moving, the cam surface on the rear of pickup cam (86) pushes lifting spindle (82) upward, raising the pickup arm clear of the record. Pickup cam (86), still moving, contacts pickup lever (78), which is connected to pickup arm (16). As pickup lever (78) moves outward, so must the pickup arm move outward toward pickup rest body (8).

After cam gear (86) has raised the pickup arm and is moving it outward, cam gear (86), still rotating, contacts release lever (122), through the action of record spindle cam (150) lower part of cam gear (86). Release lever (122) then actuates record spindle (38), thereby dropping a record to the turntable.

TROUBLE CHART (Con't)

Symptom	Cause	Remedy
	4. Dirt on turntable spindle thrust washers (46) and (49).	4. Remove turntable and turntable spindle (45). Clean ball bearings (47) and thrust washers (46) and (49). Examine the bearing faces of the thrust washers; they should be perfectly smooth, flat, and free from blemishes. If necessary, replace with new ones. Then apply a very thin grease on reassembled turntable spindle (45).
Automatic trip fails to function properly.	1. Friction lever (126) has too light friction, causing the striker (point "A" on Exploded View) to contact trip pawl (127) and push it back. Thus, it will not engage again for several revolutions of the turntable, causing the trip to fail. 2. Friction lever (126) is obstructed by dirt on face of cam gear (117).	1. Increase pressure of friction spring (130) by removing spring clip (129) and friction spring (130). Carefully bend friction spring (130) slightly and replace it. 2. Dismantle trip pawl (127) by removing spring clip (129) and examine trip pawl (127) for dirt or burrs. Remove all obstructions.
Record sound distorted.	1. Defective cartridge. 2. Defective amplifier. 3. Defective wiring. 4. Loose cartridge terminal clips.	1. Replace. 2. Check phonograph amplifier and speaker. If defective, repair or replace. 3. Check pickup leads for short or open lead. 4. Remove, squeeze together slightly, and replace.
Record does not drop when changer cycles.	1. Release spring (125) disconnected. 2. Record spindle (38) latches stuck.	1. Replace release spring (125). 2. Clean record spindle (38) and remove all obstructions.
Turntable does not revolve when manual control is turned on.	1. No current at motor. 2. Motor defective. 3. Intermediate wheel not engaging turntable rim.	1. Check that current is reaching AC leads of changer and that switch functions properly. 2. Remove turntable to allow motor to operate without load. If current is reaching motor and pulley does not rotate, the motor is defective. Repair or replace. 3. Check that tension spring (58) is in place. If not, replace. Also check for oil or dirt on intermediate wheel and rim. Clean with naphtha or alcohol.

conscriptor.net

Pickup Setdown

To set the pickup dropping position, place a record on record spindle (38), switch on the changer, and when the record drops, switch off the changer with the Stop button. Slowly turn the turntable by hand until the stylus point is about 1/8" above the record. By viewing from the front, the position of the stylus in relation to the record can be seen. To gain access to the adjustment, lift the pickup arm as far as it will go. On pickup arm pivot bracket (28) are a large and a small slotted screw head. Release the small screw and turn the large one (point "B" on Exploded View), which has an eccentric attached to it, a fraction of a turn. Then lower the arm and check the stylus position. If further out, turn the large screw in the opposite direction. When the correct position is found, retighten the small screw.

Pickup Height

Adjust the pickup height by turning height adjusting screw (23), at top rear of the pickup arm, clockwise to raise and counterclockwise to lower the pickup.

Stylus Pressure

Stylus pressure counterbalance screw (18) is at the rear of the pickup arm and is serrated for easier finger adjustment. Turning the screw clockwise reduces the pressure; counterclockwise, increases it. Set the height so that the stylus point is 1" above the top face of one record on the turntable when the pickup has lifted and is returning to its rest.

Stylus pressure should not exceed 10 grams.

Record Selector Arm

The position of selector arm (4) is set initially with the screw in the bushing of selector lever (92), at the lower end of the selector arm assembly. The final fine adjustment is made by turning eccentric adjustment screw (3) on top of selector arm (4). This adjustment is the only one that should be used for normal servicing. At the top rear of selector arm (4) are three screws. The small center screw is eccentric adjustment screw (3). To adjust, loosen the outer screws (2), turn the center one, then retighten the two outer screws.

TROUBLE CHART

Symptom	Cause	Remedy
Pickup arm fails to track. (The stylus jumps the record grooves.)	1. Worn stylus.	1. Replace stylus.
	2. Pickup leads binding the movement of the arm.	2. Loosen pickup leads.
	3. Insufficient stylus pressure.	3. See stylus pressure adjustment under "Adjustments."
	4. Trip pawl (127) not free, and its movement is obstructed by dirt on the face of cam gear (117).	4. Clean the face of cam gear (117).
Erratic Turntable speed.	1. Stepped pulley on motor shaft is loose.	1. Tighten stepped pulley
	2. Incorrect position of stepped pulley.	2. Intermediate wheel should engage the correct pulley step, according to the speed indicated by the knob.
	3. Oil or dirt on inside of turntable rim, motor pulley surface, or face of intermediate wheel (56).	3. Wipe with a clean rag to remove all traces of dirt or oil.
Rumble.	1. Motor bearings dry.	1. Oil sparingly.
	2. Motor not free on its rubber suspensions.	2. Reposition the motor on its rubber suspensions.
	3. Motor leads binding.	3. Loosen motor leads.

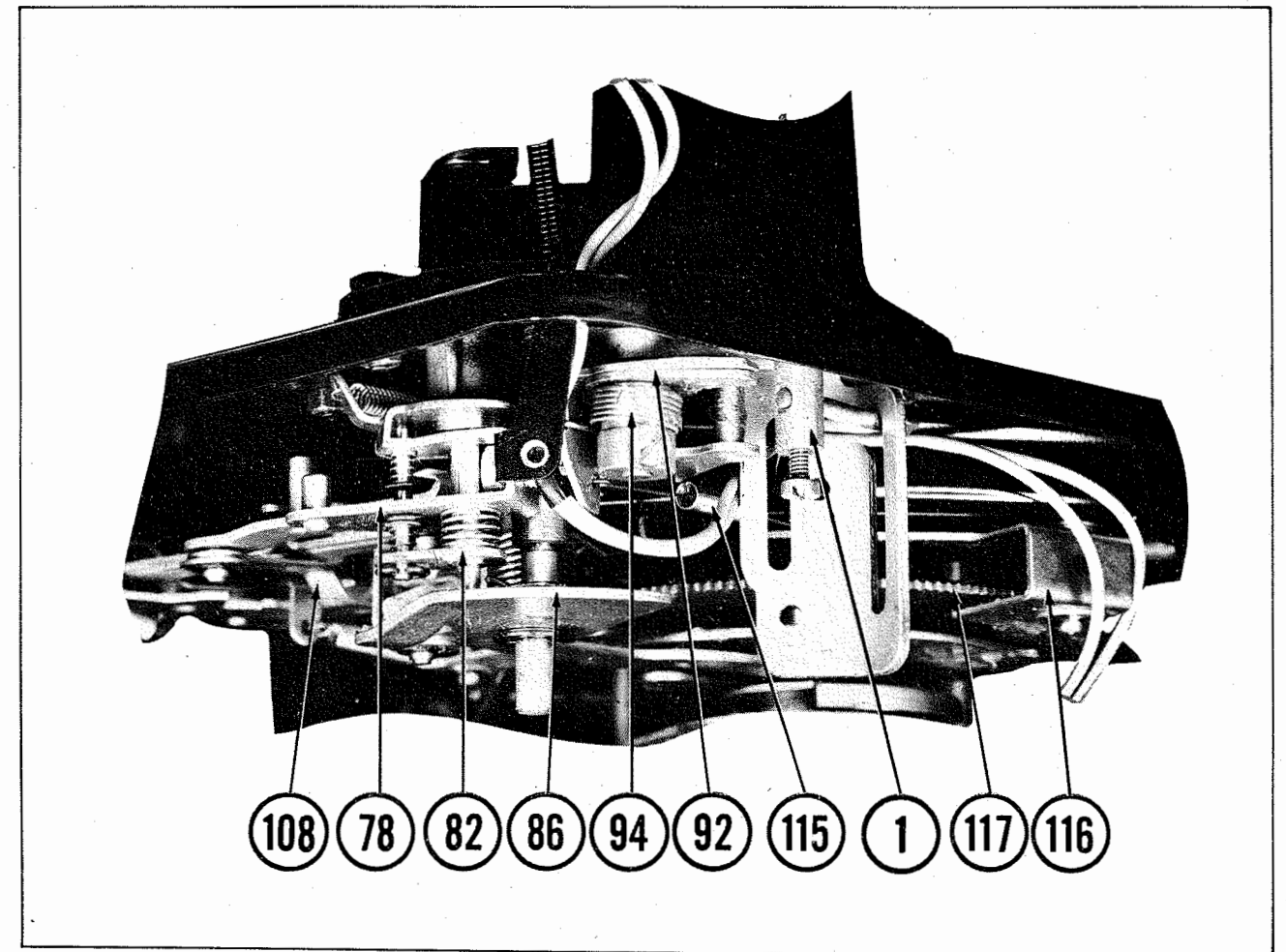

FIG. 4 SIDE VIEW OF TONE ARM OPERATING MECHANISM

Simultaneously, record selection takes place. To observe how 10" and 12" records are selected, place a 10" record on the record spindle with a 12" record above it. Now move overarm (1) inward. Selector arm (4) moves inward, allowing the transparent plastic record selector attached to it to touch the edge of the 12" record, with the flared portion of the record cam projection underneath the record. When the 10" record drops, the selector arm is moved back. Selector lever (92) is connected to the bottom of the selector arm shaft and is moved back at the same time. Selector lever (92) is now in the 10" position. As the pickup arm moves in toward the spindle, interselector lever (76) drops into the 10" notch on selector lever (92), stopping the pickup arm over the 12" record lead-in groove. With a 7" record, selector arm (4) is moved farther than with the 10" and 12" records. Therefore, interselector lever (76) drops into the 7" notch on selector lever (92), stopping the pickup arm over the 7" record lead-in groove.

While the cam gear continues rotating, cam link (85) changes direction, thereby moving pickup cam (86) back to its original position. This action allows the lifting spindle to move down and the pickup to set down on the record. As the pressure is released from lifting spindle (82), cam gear (117) is at a point where the teeth run out and the turntable spindle no longer controls its movement.

After the mechanism has been tripped, it again follows the preceding sequence of cycling and playing the records until the last record of the stack has been played.

As the last record of the stack drops to the turntable, the pickup arm is moved back to pickup rest body (8). Selector arm (4) also moves toward record spindle (38), seeking the edge of the record. Because the last record has dropped, selector arm (4) moves almost to the center of the turntable, taking selector lever (92) with it, which pivots knock-off lever (107) toward record spindle (38). Because the auto. stop lever is connected to knock-off lever (107) by a friction arrangement, the auto. stop lever is also moved toward record spindle (38). When the knock-off lever is moved inward far enough to engage the projection on cam gear (117), the knock-off lever is forced back toward the pickup arm, forcing control link (75) back and out of engagement with stop catch lever (104). Control lever (73) is then free to move to the off position. As control lever (73) moves to the off position, switch lever (43) actuates switch block (42), removing power from the motor and stopping the mechanism.

As cam gear (117) moves to the out-of-cycle position, lifting spindle (82) rides down the incline of pickup cam (86), lowering the pickup arm to the pickup rest body (8).

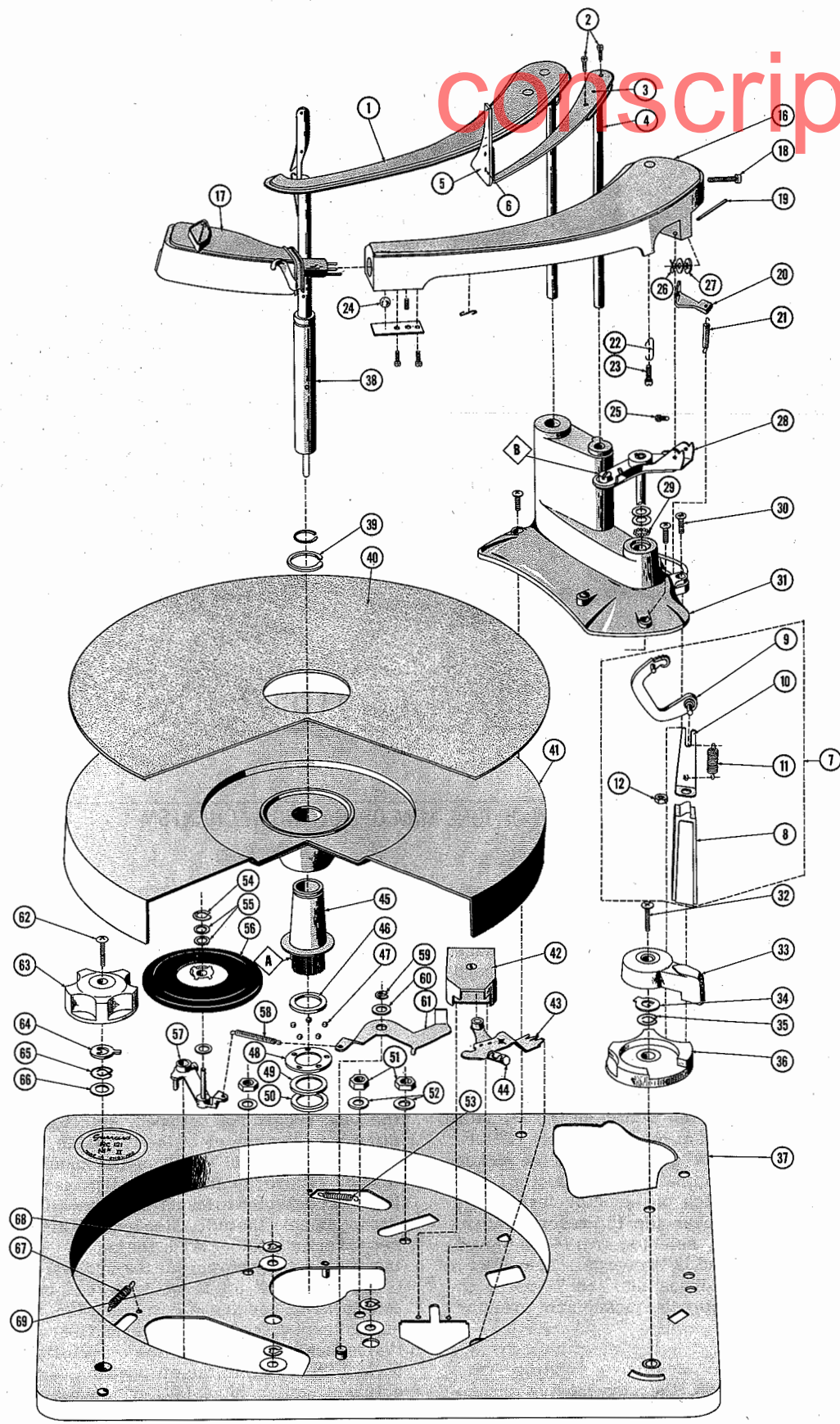

A PHOTOFACT "EXPLODED" VIEW
©Howard W. Sams & Co., Inc. 1958

FIG. 5A EXPLODED VIEW OF PARTS ABOVE BASEPLATE

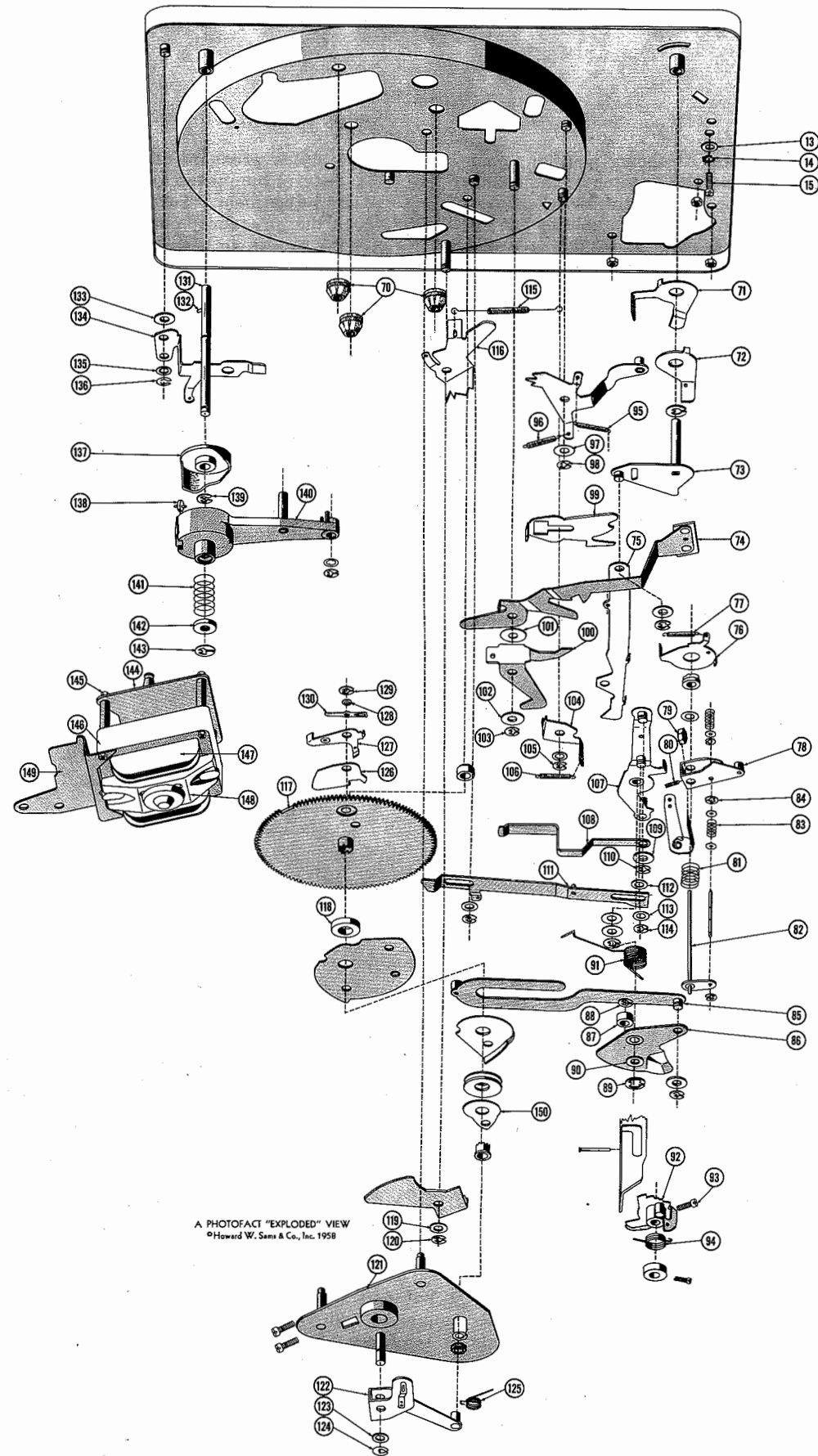

A PHOTOFACT "EXPLODED" VIEW
©Howard W. Sams & Co., Inc. 1958

FIG. 5B EXPLODED VIEW OF PARTS BELOW BASEPLATE