

## SERVICE ELECTRICAL and RADIO CHARTS TRADING

BEETHOVEN A1188  
GARRARD RC70  
McCARTHY MC422  
REGENTONE RG99/2

### GARRARD AUTOMATIC RECORD CHANGER, MODEL RC70

THE changer (Fig. 1) is a self-contained brown-enamelled unit (Fig. 1) on a 15 by 11½-in. plate, requiring cabinet fitting space 15½ in. long by 13 in. wide, with 5½ in. clearance above and 2½ in. below. Spring suspension is fitted.

The constant speed induction motor turns the table at 78 rpm. The turntable, which is rim driven by a pulley on the motor via a floating rubber-tyred intermediate wheel (Fig. 2), locates on a brass driving collar integral with the main spindle 132 (Fig. 4), to which is fixed a concentric pinion 171. When the turntable is removed the motor can run free, being disconnected from the changing mechanism, which can be worked by hand by revolving the main spindle on pushing knob to "Reject."

Record spindle 133 of the Garrard bent type fits into the hollow main spindle and locks into locating plate 168.

Records placed on the spindle are supported on one side by the platform. If the records are 12 in., the 10-in. platform and pawl are lowered by putting the selector lever in the 12-in. position, thus leaving the 12-in. pawl to push the records from the platform. Position of the selector lever causes the pick-up to drop correctly on the edge of the record,

#### OPERATION

One revolution of main cam unit 50 (Fig. 3) completes one changing cycle. With 10 records on the spindle, clip lowered and selector lever in correct position, the control knob is moved to "Start." This closes the switch via switch link lever 83, which is then locked by the spring-loaded catch lever 85. Trip lever 106 is knocked back by the reject lever 82 and releases the V-shaped impulse lever 43. This is biased with a strong spring, so that when released it knocks a projection on the inner diecast cam of the cam unit 50, which is integral with the gear assembly. The gear

assembly is thus given an impulse, which brings gear segment 55 into mesh with the pinion on the main spindle, commencing the changing cycle.

Outer cam of revolving cam unit 50 operates coupling link 164, which in turn, via lever 146, moves pawls 142 and 144 to push off the lowest record.

Outer cam, via the lifting lever 100, lifting link 174, lifting crank 194, and lifting spindle 180, controls the lift of the pick-up arm. Swing lever 42, operated by the inner cam, prevents the arm going into the record until it has lifted, when it slowly swings out of the way, allowing the arm to go in by the pull of spring 119 until it reaches the correct dropping position, determined by the pick-up selector lever 172, when the lifting link falls into a slot in the diecast cam, allowing the arm to lower gently on to outside edge of record. The gear wheel comes to rest so that the non-toothed portion is in front of main spindle pinion, and the main spindle revolves free of the mechanism.

**Selector Mechanism.** When selector knob is moved to 10 or 12-in. position, besides setting the record platforms, it moves the pick-up lever 41 into the 10 or 12-in. position. When a record has finished playing, and the auto-trip sets in motion the main cam, the lifting mechanism 100, 174, 194, 180 lifts pick-up off the record. The closing of two felt faced discs attached to lifting crank 194 (Fig. 4) and lifting spindle 180 respectively prevent the pick-up from swinging out of position.

Immediately the needle is clear of 10 records

on the turntable, swing lever 42 moves in, roller 39 engages edge of pick-up lever 173 and swings pick-up outward until selector lever 172 is stopped by pin on lever 41 in the correct dropping position. Swing lever continues to swing 173 outward, putting a tension on spring 119, which couples lever 172 and the pick-up lever 173.

If there are no more records on the spindle and the clip has fallen, swing lever 42 remains in, locking pick-up and motor is switched off.

If there are records to be played or the clip is raised up to repeat the last record, swing lever 42 moves outward, releasing the pick-up unit and allowing the spring 119 to contract, pulling the pick-up selector lever and the pick-up lever together until they become solid. As the pick-up selector lever is held in the pick-up dropping position as explained above, the solid position occurs when the needle is in the correct position to be lowered on to the edge of the record. At this point the lifting mechanism lowers the needle on to the record and finally parts the felt-faced discs.

**Auto-trip Mechanism.** When needle has alighted on record, the main cam continues to revolve for a fraction of a turn, during which it moves impulse lever 43 back into its original position, where it is locked by engaging in catch in trip lever 106.

Two separate auto-trip mechanisms are provided:

(1) For recordings which have an eccentric run-off groove a mechanism operates the changing

*The RC70 plays up to ten 10-in. records or ten 12-in. records, but not mixed, and is suitable for use on 100-130 and 200-250 volts 50 c/s AC. Driving pulleys for 40 or 60 c/s mains can be supplied. The plug-in magnetic pick-up is interchangeable with a crystal type. Made by the Garrard Engineering and Manufacturing Co., Ltd., Swindon.*

mechanism on the reverse motion of the pick-up arm. When the needle reaches approximately 3¼-in. radius a leaf spring pawl 175 commences to slide gently along the serrations on tail of the trip lever 106, when the needle commences to oscillate in the eccentric run-off groove, the reverse motion imparted to the pawl causes it to catch in the serrations and pivot the trip lever, so releasing 43, which knocks cam gear into mesh with revolving main spindle pinion as outlined earlier.

(2) For recordings where the run-off groove is carried in to a standard small diameter the roller on stop link 112 is provided. When the needle reaches 1½-in. radius the roller makes contact with the trip lever 106, pivoting it and setting the changing cycle operating, as in the previous paragraph.

In later models pawl plate 111 is given a limited amount of movement, independent of pick-up lever 173, controlled by a light spiral spring. This is to desensitise the pawl to prevent it prematurely tripping the mechanism when the needle oscillates on records that are slightly out of true.

When last record has dropped on to turntable the clip is pulled down by spring 149, pivoting knock-off lever 155 and knock-off extension 163. A catch in 163 then engages lever 42, preventing it moving out to release the pick-up unit and forcing it to follow another path in the inner cam, a node on which causes lever 42 to give an impulse to the trip link 90, which in turn pivots the catch lever releasing the switch lever 88 and thereby opening main switch and stopping the motor.

To allow a record to be played directly on the turntable or repeated when the clip is down as the control knob is moved to "Start," the friction lever 80 lifts the knock extension to allow the swing lever to clear the catch and move out to free the pick-up unit.

#### ADJUSTMENTS

**Speed.** No adjustment for speed is provided. The driving surface of the small brass pulley on the motor spindle, the rubber-tyred pulley and the drum of the turntable must all be kept free from oil or grease.

**Noise.** Should the motor become noisy, apply a few drops of fine lubricating oil.

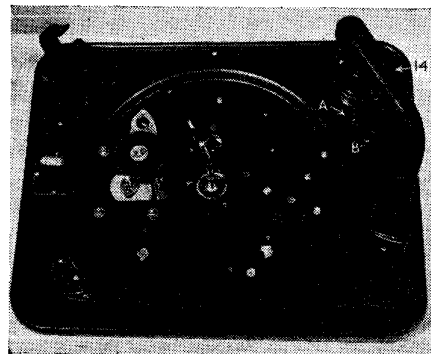
**Power Consumption.** The motor is designed to run at higher temperature than usual. Should the motor get excessively hot, see that the voltage change-over links are set correctly. If correct, check motor windings by inserting an AC milliammeter in either motor lead. Maximum current should not exceed on 100-130 V, 50 c/s, 0.26 amp., on 200-250 V 50 c/s, 0.13 amp.

**Removing Motor.** Remove insulated plate on the underside of the terminal block, and unscrew bolts holding block to unit plate. While supporting the motor, under-

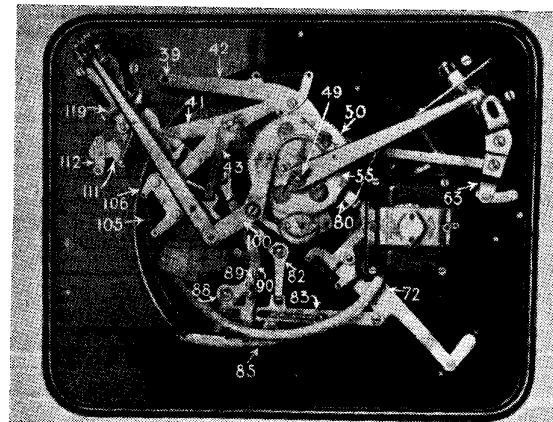


Fig. 1.—The model RC70 plays ten 10 in. or 12 in. records, not mixed

Right: Fig. 2.—With turntable removed, the drum-drive wheel is seen. A indicates location of pick-up position-adjusting screw and B is an auto-trip adjuster



Right: Fig. 3.—The "works" of the changer with parts keyed to the text



**BETHOVEN AII88**

T2 are MW bandpass trimmers. AVC, decoupled by R20, C45, is applied through R5.

Oscillator is connected in a shunt-fed tuned-anode circuit. The anode coils L37, L39, etc., are switched by S10, through C31, to oscillator anode, of which R9 is the load. The MW coil L57 is provided with trimmer T3 and padder C43. The oscillator tuning capacitor VC3 is switched by S12 through series capacitors C33, C35, C37, C41, C42 to S11 and thence to the coils. On SW1 band C34 is shunted across VC3, whilst C32 is placed across the tuned circuit on all ranges. For the SW bands other than SW1, C44 is placed across VC3.

The grid reaction coils L36, L38, etc., are switched by S9 through C30 to oscillator grid of V2. Automatic bias for grid is developed on C30 with R8 as leak.

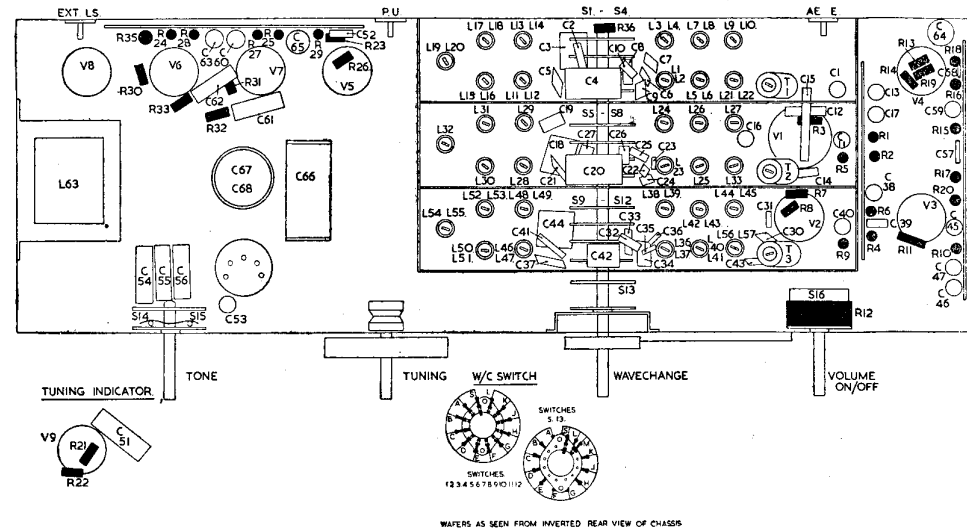
IF amplifier operates at 465 kc/s. Secondary L35, C29 of IFT1 feeds signal and AVC voltages, decoupled by R20, C45 to g1 of IF amplifier V3. Cathode bias is provided by R11 and decoupled by C46. Screen (g2) voltage is obtained from R10 and decoupled by C47. Suppressor grid (g3) is strapped to cathode. L58, C49, which form the primary of IFT2, are in the anode circuit.

Signal rectifier. Secondary L59, C50 of IFT2 feeds signal to one diode of V4. R16 is load, and R15, C57, C58 form an IF filter.

Tuning indicator. The DC component of the rectified signal is tapped from potential divider R13, R14 and fed to C51 and grid of tuning indicator V9. Cathode is coupled to cathode of V4. R21, R22 are anode load resistors. Target anode voltage is taken from HT line.

AVC. C48 feeds signal from primary of IFT2 to second diode of V4. R19 is its load. AVC voltages decoupled by R20, C45 are fed to control grids of V2 and V3. Cathode voltage of V4 provides a delay bias for the AVC diode.

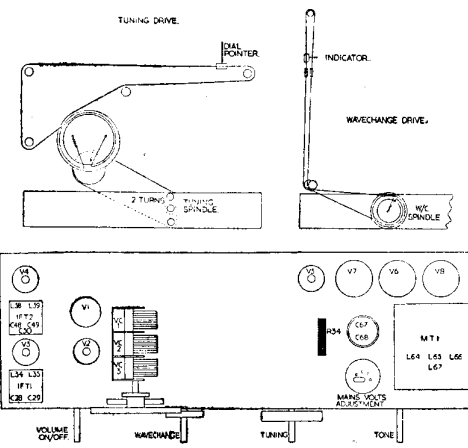
Continued on page 48



**TRIMMING INSTRUCTIONS**

Apply Signal as Stated Below	Tune Receiver to	Trim in Order Stated for Max. Output
(1) 465 kc/s to fixed plates of VC2 via .01	MW 530 metres	Core L59, L58, L35, L34
(2) 600 kc/s to AE socket via dummy aerial	500 Metres	Core L57, L33, L22
(3) 1.4 mc/s as above	214 metres	T3, T2, T1 and repeat (2) and (3).
(4) SW Bands		

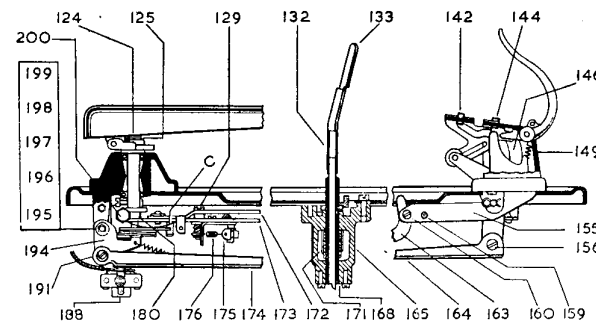
Alignment of the bandspread ranges should be effected with great care as the normal signal generator is not accurate enough for satisfactory adjustment. Alignment in the factory is effected with crystal controlled apparatus. Should any adjustment be necessary, the receiver should be tuned to a station of known frequency and the oscillator, HF and aerial inductances adjusted in that order for max. output.



**GARRARD RC70 AUTO-CHANGER**

from page 43

Fig. 4.—Details of the pick-up control gear, centre spindle and record platform



neath, unscrew the nuts on the three suspension screws, which secure the motor to the unit plate. Before drawing the motor away from the unit plate, note the sequence of steel and rubber washers on each suspension screw.

**Pick-up Dropping Position.** The pick-up arm has been finely adjusted so that the needle comes on to 10-in. records in a 9 3/8-in. diameter circle and 12-in. records in a 11 3/8-in. diameter circle. Should the position require adjustment, the pick-up adjusting screw—accessible through a hole in the unit plate (A and 129)—should be turned with the changer in its start position, that is, with the pick-up arm on its rest. A quarter of a turn in either direction gives maximum adjustment.

Should pick-up arm have been forced out of position and the adjustment provided by the screw be insufficient, operate the changer and allow it to switch off automatically, when the pick-up arm will be locked on or near the rest. Loosen the hexagonal headed screw 200 (do not attempt to turn the nut)—when the pick-up arm will be free, place arm centrally on rest and retighten the screw. Pick-up should now be in the correct position and any fine adjustment can be made with pick-up adjusting screw.

**Pick-up Height** can be adjusted by loosening the nut securing the eccentric 191 and adjusting the eccentric pivot with screwdriver in slot at back. Finally, retighten locking nut.

**Caution.** When making adjustments to the pick-up arm it should never be forced into position. If the turntable is turned by hand it should not be turned backward.

If the pick-up does not run into the record grooves after alighting on the record edge, see that the record changer is level by placing a spirit level on a record on the turntable. Make sure that the flexible wire leading to the pick-up is not twisted or held in such a manner as to prevent the free movement of the pick-up arm; also see that the associated levers are free.

**Auto-trip Mechanism** is set to operate when the needle reaches a 1 3/8-in. radius, or if it oscillates in an eccentric groove. Occasionally records having a smaller or larger radius at the end of the playing grooves are encountered. If it is desired to adjust the mechanism to take these exceptional records the screw B, visible through hole in unit plate, should be adjusted.

To make the trip operate earlier for larger radius records loosen the screw, and holding pick-up arm steady, move screw in slot a shade towards turntable. The screw should be moved a barely visible amount at each adjustment.

If an early model in which the pawl plate 111 is missing and the pawl pivot is attached directly to the pick-up lever 173 has a tendency to trip prematurely on records that are eccentric (swingers), carefully polish corner of impulse lever 43 that engages on catch in trip lever 106 and strengthen slightly spring 105. Also stretch pawl spring 176 to weaken it.

**Record Platform Adjustment.** To set the platform, the nut 156 locking the eccentric should be loosened, and with mechanism set for 12-in. records pick-up arm in the playing position, and the largest 12-in. record available loaded on platform, turn the "eccentric adjustment" until there is a gap of not more than 1/16 in. between the edge of the record and the front edge of the platform pawl. Finally, retighten the locking nut 156.

**Auto Stop at End of Last Record.** When the last record on the platform drops on to the turntable it allows the record clip to fall and this unlocks the auto stop, which should switch off the motor at the end of the record. If, when the last record has been played, the record clip has fallen and the mechanism does not automatically stop, the following procedure should be carried out.

Locate swing lever 42 and knock-off extension 163. Note that in the upper edge of the knock-off extension there is a step. With the record clip lowered and the needle removed from the pick-up head, start the changer

with a hand on the turntable and slow it down to the slowest possible speed at which the mechanism will operate. Move the control lever to the "Reject" position. Swing lever 42 should now move outwards until it engages step on knock-off extension, and should remain engaged until record changer switches off. If swing lever does not engage step but passes over it, proceed as at (a) to correct. If it engages in step, set as at (b).

(a) Load two records on platform spindle in the usual way. Lower record clip and start changer. First record will now drop on to turntable, leaving one remaining on the platform. Again, with the hand operating as a brake to slow down turntable, move control lever to "Reject" position. The tip of the step on knock-off extension should now clear the surface of the swing lever in its outward movement by 1/64 in. If this dimension is incorrect, stop the changer when the swing lever is directly over step in knock-off extension. Knock-off extension is attached to knock-off lever 163 by rivet 159 and adjusting screw 160. Loosen the screw to adjust height of the extension until 1/64 in. clearance is obtained, then retighten screw. Finally, re-check changer with record clip lowered to ensure that swing lever engages step. Should auto top fail to operate, set as at (b) below.

(b) Loosen screws 89 and bring the two parts of the trip link 90 together to shorten slightly the effective length and retighten the screws. Check and repeat adjustment if necessary until changer operates correctly.

**Pick-up slides across 10-in record and rejects without playing.** This is due to the gap between swing lever and changer on knock-off extension being set too fine and the adjustment described at (a) above should be carried out.

**Pick-up commences at varying distances.** The fault can be due to two causes. Firstly, ascertain that the spring marked C is present in the changer. If spring is present the fault is probably due to pick-up arm lifting too high when it returns to the rest after playing a record, and to check this stop the motor when pick-up arm is halfway back towards the rest after 10 records have been played. In this position, with a 3/8-in. long needle in the pick-up, the tip of the needle should be just clearing the surface of top record.

If clearance is greater, it indicates the mechanism is lifting arm too high, and to correct it, loosen locking nut on back of eccentric pin 191 and turn pin by means of slot in the end opposite to nut until pick-up is at the correct height, then retighten nut.

If the spring mentioned above is not fitted it may be obtained from the Garrard Service and Spares factory.

**Pick-up alights on record and immediately rises again, unit drops next record and repeats the process through all records on platform without playing any.** When unit is in playing position, i.e. the needle being on the record, there should be a slight amount of play in lever 164 discernible as a movement between pin 49 and end of slot in lever 164. If no movement is present, slightly adjust eccentric pin 156 to produce it.

There should be a clearance between the end of reject lever 82 and trip lever 106. If not, gently bend reject lever 82 slightly away from trip lever 106.

Occasionally, due to either spring 105 being weak, or to trip lever 106 being sluggish on its pivot the impulse lever 43 does not engage catch inside trip lever, but moves back in to give the pin on the cam the impulse to recommence the changing cycle, in which case free trip lever and strengthen spring as necessary.