

EVER READY MODEL K PORTABLE

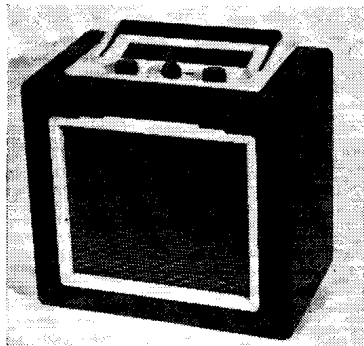

Four-valve, two-waveband all-dry battery superhet in sprayed finished cabinet fitted with moulded plastic dial escutcheon and carrying handle. Weight with batteries 16 lbs. Marketed by The Ever Ready Co. (Great Britain) Ltd., Hercules Place, Holloway, London, N7.

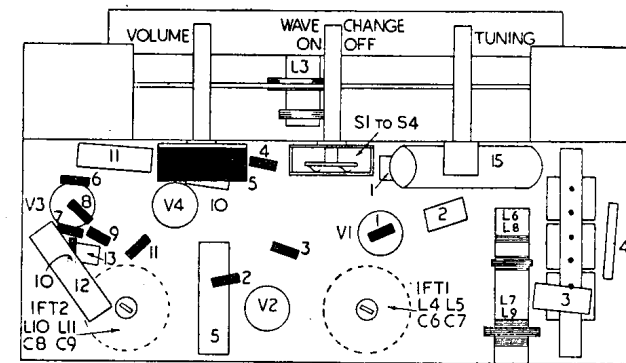
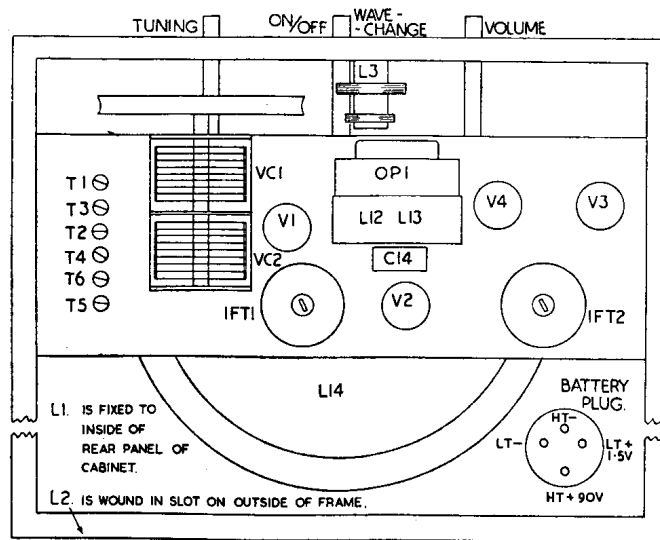

R	10	7	6	9	11	5	4	3	1
C	8	9	12	13	10	5	1	6	7
L	10	11				3	4	5	6

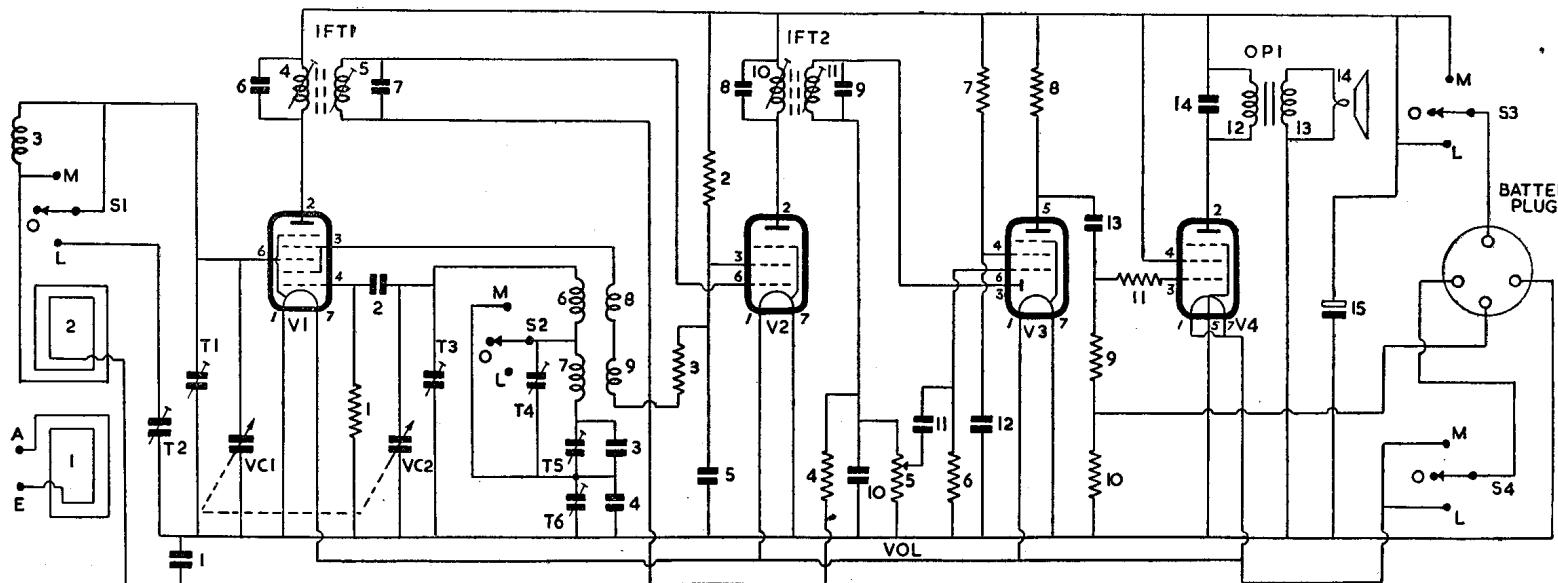
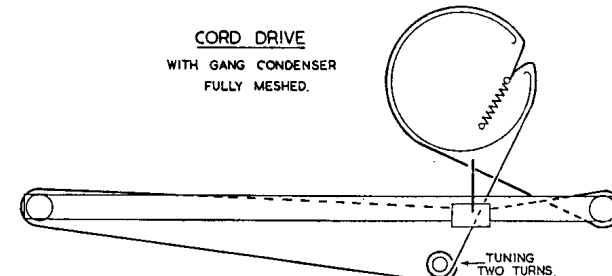
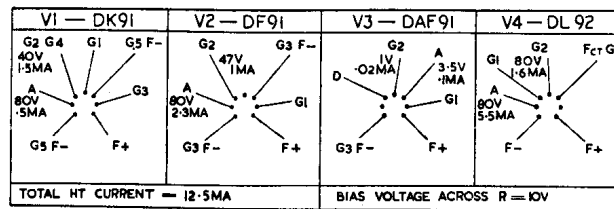

CAPACITORS

C	Capacity	Type
1	.05 Tubular 350V	
2	100pF Silver Mica	
3	200pF Silver Mica	
4	500pF Silver Mica	
5	.1 Tubular 350V	
6	100pF Silver Mica	
7	100pF Silver Mica	
8	100pF Silver Mica	
9	100pF Silver Mica	
10	100pF Silver Mica	
11	.001 Tubular 350V	
12	.1 Tubular 350V	
13	.001 Tubular 350V	
14	.001 Tubular 350V	
15	8 Electrolytic 150V	

RESISTORS

R	Ohms	Watts
1	100K	
2	10K	
3	4.7K	
4	2.2M	
5	500K	Potr.
6	10M	
7	4.7M	
8	1M	
9	4.7M	
10	820	
11	2.2M	

INDUCTORS

L	Ohms
1	.5
2	1.5
3	9.5
4	9.5
5	9.5
6	3
7	6
8	3
9	8.5
10	9.5
11	9.5
12	500
13	.25
14	.25

Continued on page 38

ALBA T331, T431, T432

Continued

DC-AC coupled by R23, R24, C19 to cathode of CRT.

Interference suppressor consists of diode V5B and network R19, C17 connected between anode of V6 and chassis. C17 charges up through R19 to a potential approximately equal to peak-white. With the cathode of V5B following the video signal the diode will normally remain cut off. When a large amplitude short duration pulse appears with the video signal at anode V6 then, because of the long time constant of R19, C17, the cathode of V5B is driven negative, the diode conducts and short circuits the pulse.

Sound channel. The sound signal of 41.5mc/s is amplified with the vision signal by V1 to V3 and is capacity coupled by C13 to L16, C34 (tuned to 41.5mc/s) in the grid circuit of first sound RF amplifier V8. The grid tuned circuit L16, C34 also functions as a sound on vision rejector for the vision channel.

V8 is coupled by a single peak transformer L17, L18 to the second sound RF amplifier V9, which in turn is choke-capacity coupled by L19, C40, L20 to signal rectifier V10A. The rectified signal across R48 is fed by C42 through series noise limiter V10B and filter R52, C44, C45 and coupled by C46 to volume control R53. After amplification by output pentode V11, the audio signal is fed into a 5in. PM speaker.

Noise limiter. Anode V10B is positively biased from the HT line through R50, R51. It conducts and sets up a potential across cathode load R49. In the anode circuit the time constant of R50, C44 is such that voltage across R50 will follow that of the audio signal. When a large amplitude short duration interference pulse is passed by C42 then V10B is cut off—due to the sudden positive potential applied to its cathode—its anode potential remaining unaltered because of comparatively long-time constant of R50, C44. Hence during the period of the interference pulse no signal is passed by V10B.

Sync separator. Signal at anode of video amplifier V6 is fed through R73, C21 to grid of sync separator V7. The positive sync pulses drive V7 into grid current which produces across R25 a steady negative bias. The bias places the negative picture signal beyond cut-off and thus only the positive sync pulses appear in the anode circuit. The frame pulses developed across R27, C23 are integrated by R26, C25 and fed to screen and suppressor of frame oscillator V15. The line sync pulses developed across R28 are fed by C50 to screen of line oscillator V12.

Frame scan oscillator is pentode V15 coupled in a self-oscillating circuit. Frequency is controlled by adjustment of the positive bias applied to its grid by Frame Hold control R39. The waveform is amplified by output pentode V16 and fed through C33 to the high impedance frame deflector coils L14, L15 on the neck of the CRT. R36, which provides adjustment of amplitude of input waveform to grid of V16, is the frame amplitude control. Negative feedback from anode to grid is given by C31, R38, R40.

Line scan oscillator is a pentode V12 operated as a grid-blocking oscillator with screen to grid transformer back-coupling by LT1. Adjustment of time constant of R57, R56, C49 in the grid

VALVE READINGS

V	A	G2	K	Notes
1	230V	230V	2V	—
2	210V	210V	1.8V 5 V	Max. Contrast Min. Contrast
3	210V	210V	1.8V 5 V	Max. Contrast Min. Contrast
4	230V	230V	2 V	—
6	210V	230V	7 V	—
7	190V	50V	—	—
8	150V	150V	1.4V	—
9	150V	150V	1.4V	—
11	190V	195V	5 V	1A—26mA G2—3mA
13	90mA	10mA	30 V	Min. amp.
14	—	—	5.5kV	—
15	120V	180V	—	—
16	100V	230V	5 V	—
17	310V RMS	—	325 V	Total HT Current—225mA
18	A2 5.5kV	A1 320V	K 75V	G1 0-300V.

circuit by variation of R56 the Line Hold control, regulates frequency. The scan waveform developed on C52 is fed by C51, R60 to output pentode amplifier V13. Secondary L27 of line output transformer LT2 in the anode of V13 feeds waveform to the low-impedance deflector coils L29 on the neck of the CRT.

On certain models the line coils are damped by a resistor R64 and are fitted with an adjustable linearity circuit consisting of an iron cored inductance L30 and a variable resistor R66 in series with R65, C56. Capacitor C53 feeds the line flyback pulse to the grid of V13 to ensure that it is held cut-off during the whole of the fly-back period. Line Amplitude control R63 varies the amount of cathode negative feedback to V13.

EHT of approximately 5.5kV for the final anode of CRT is obtained by V14 rectifying the high surge voltage set up across the overwound primary L26 of line output transformer when V13 is cut-off. An auxiliary secondary L28 supplies the rectifier heater current. The EHT is capacity smoothed by C55 (or alternatively by the capacity between inner and outer coatings of CRT), and fed direct to final anode of CRT.

Screen voltage of CRT is obtained from C68, the smoothing capacitor immediately following the choke.

HT is provided by an indirectly-heated rectifier V17 connected in a halfwave circuit. Its anode voltage is obtained from the mains auto-transformer L33 through current limiter R70. A separate secondary L32 provides the rectifier heater current. Choke-capacity and resistance-capacity smoothing is given by L31, R67, R68, R69 with C65 to C69. C69 should be rated to handle 500mA ripple current.

Heaters of V1 to V13, V15 and V16 are series connected and obtain their current through surge

limiter R71, R72, from a tapping on the mains auto-transformer winding L33. C57 to C64 are heater to chassis by-pass capacitors.

CRT heater is provided with a separate section on the auto-transformer winding. On earlier versions of this receiver the CRT heater was connected to a tapping at opposite end of valve chain.

MT1 is tapped for inputs of 200, 215, 230, 240V 50c/s and is provided with a 1A fuse in voltage adjusting plug. S1, which is a double pole switch ganged to the sound volume control spindle, is the ON-OFF switch.

CRT is either a 9 or 12in. tetrode with PM ring focussing. Brilliance is controlled by adjustment of grid bias by R29.

TRIMMING INSTRUCTIONS

1. Connect high-resistance voltmeter (5V) across vision channel diode load R18. If a high resistance voltmeter is not available then a 100 microammeter can be used with a 50K series resistor. It should be connected one side to chassis and the other side plugged into socket provided at side of V6.

EVER READY MODEL K

Continued from page 35

AERIAL. The receiver is fitted with a MW frame aerial L2 and loading coil L3 for LW reception. Sockets connected to a coupling loop L1 are attached to the inside of rear panel and enable an external aerial and earth to be used.

Oscillator is connected in a tuned grid, series fed circuit. The grid coils are connected in series and connected to oscillator tuning capacitor VC2 and coupled by C2 to oscillator grid (g1) of V1. On MW band L7, T4, T5 are short circuited by S2 and L6 is tuned by VC2, trimmed by T3 and padded by T6, C4. On LW band the short circuit across L7 is removed and L6, L7 are tuned by VC2 trimmed by V4 and padded by T5, C3.

IF amplifier operates at 452kc/s. Signal rectifier. Secondary L11, C9 of IFT2 feeds signal to single diode of V3. R5, the volume control, is the diode load and C10 diode reservoir.

AVC is provided by DC component of rectified signal which is developed on C10 and fed through decoupling network R4, C1 to V1 and V2.

AF amplifier. C11 feeds signal from volume control R5 to pentode amplifier section of V3.

Output stage. Signal at anode of V3 is coupled by C13 through stopper resistor R11 to pentode output valve V4. Negative bias is obtained by returning earthy end of grid resistor R9 to chassis through bias resistor R10 which is in the negative HT lead.

HT of 90V is obtained from an Ever Ready battery type B103 and is decoupled by C15. S3 which is ganged to the wave-change switch and in the positive lead is the HT ON/OFF switch.

Filaments of V1 to V4 are connected in parallel and obtain their current of 250mA from the 1.5V LT section incorporated with the HT battery. S4, ganged to S3 and in the positive filament lead, is LT on-off switch.

Chassis removal. Remove back of cabinet by turning inwards the two screws at top. When the back is off, the chassis with dial escutcheon, knobs and frame aerial can be withdrawn by placing the fingers of the righthand under the chassis and the thumb on the output transformer and gently pulling.

2. Inject 46.5mc/s to V4. Connect 500 ohm damping resistor across L9, L11. Adjust core L10 for maximum deflection on meter.

3. Disconnect damping resistor from L9, L11 and connect it across L10. Adjust core L9, L11 for maximum deflection.

4. Repeat operations (2) and (3) until no further improvement is obtainable.

5. With damping resistor disconnected swing signal generator from 45 to 48mc/s. The output should be substantially level.

6. Connect signal generator to aerial input socket.

7. Inject 49mc/s and adjust core of L7, L8 for maximum deflection.

8. Inject 45.5mc/s and adjust core L5.

9. Inject 47mc/s and adjust L3.

10. Inject 45mc/s and adjust core L1, L2.

11. Inject 41.5mc/s and adjust core L16 for minimum deflection.

12. Inject modulated signal of 41.5mc/s and adjust cores L19-20, L17-18 for maximum sound.

To replace chassis, lay cabinet face downward on bench and lower chassis into it, taking care to guide escutcheon over top edge of cabinet.

Renewal of drive cord. Remove the three control knobs. Undo the three screws securing plastic escutcheon plate to rear top edge of frame aerial and lift off escutcheon complete with carrying handle.

Next remove bolts and insulating washers securing scale plate to chassis brackets and lift off scale. The new drive cord can now be fitted as shown in diagram.

When replacing scale, check that oiled silk strips and insulating washers are correctly reassembled to provide good insulation between scale and chassis.

TRIMMING INSTRUCTIONS

Apply signal as stated below	Tune receiver to	Trim in order stated for maximum output
------------------------------	------------------	---

(1) The receiver RF circuit may be adjusted with the chassis, etc., in or out of the cabinet, provided that the HT battery is placed in same position as it occupies in normal use.

(2) Check that with gang at maximum capacity the dial pointer coincides with right-hand end of scale mark.

(3) Connect Sig/gen to a loop placed approximately 12 inches away from frame aerial of receiver.

(4) 1.4mc/s to loop	215 metres	T3, T1
(5) 600kc/s as above	500 metres	T6. Repeat 4 and 5
(6) 176.5kc/s as above	1700 metres	T5
(7) 300kc/ as above	1000 metres	T4, T2. Repeat 6 and 7

The IF circuits are factory adjusted and sealed and should not be interfered with unless absolutely necessary.

If alignment is necessary then proceed as follows:—
(8) Remove receiver chassis from cabinet—remove LS baffle from front bracket of assembly (do not unsolder LS lead). Disconnect the green lead from frame aerial.

(9) 452kc/s to g3 of V1 (green lead disconnected from frame aerial).	LW Band	Cores L11, L10, L5, L4.
--	---------	-------------------------