

EVER-READY MODEL C

Model C All-Dry Portable 4-valve, 2-band superhet in cream plastic cabinet. Internal aerial. Powered by Batrymax B103. Made by Ever-Ready Co. (G.B.), Ltd., Hercules Place, Holloway, London, N7.

CIRCUIT consists of a pentagrid frequency changer V1, followed by an HF pentode V2 used as IF amplifier. A single diode-triode V3 is used as second detector, AVC and AF amplifier. A pentode output valve, V4, provides approximately 240 mW output.

Aerial circuit: Frame aerial L1 (MW) and L2 (LW), connected in series; on MW, S1 short-circuits L2. VC1 is aerial tuning capacitor; T1 is MW and T2 is LW trimmer. Aerial is coupled direct to control grid of V1 and AVC is led to grid in series with L1 and L2.

Screen voltage is obtained from R1 and decoupled by C1. Primary L7, T7 of IFT1, is in the anode circuit of V1.

Oscillator is connected in a tuned grid circuit, the windings L3 (MW), L4 (LW) being series connected. On MW, S2 short-circuits L4. VC2 is oscillator tuning capacitor; T3 and T4 are MW and LW trimmers; T5 is MW padder, T6 LW padder.

C2 is grid coupling capacitor, and R2, C2 provide leak-condenser bias for oscillator grid. The oscillator HT is supplied through the series connected anode reaction windings L5 (MW) and L6 (LW).

IF Amplifier operates at 452 Kc. Secondary L8, T8 of IFT1 feeds signal to grid of V2, the IF amplifier valve. AVC is fed to grid in series with secondary winding of IFT1. Screen voltage V2 is obtained direct from HT line. L9, T9, the primary of IFT2, is in the anode circuit.

Second Detector and AVC.—The single diode of V3 is used for signal rectification and AVC. L10, T10, the secondary of IFT2, feeds the signal to diode anode. R6, the volume control, is the diode load resistor. R5, C4, C5 form an IF filter circuit.

Only part of the rectified signal is used for AVC and R3, R4 form a potential divider for this

purpose. AVC line is taken to junction of R3, R4. C3 is a decoupler.

AF Amplifier is the triode section of V3. C6 feeds the signal from volume control R6 to grid of V3. R7 is grid resistor; leak-condenser bias for triode grid is obtained from R7. C6. R8 is anode load resistor and C8 is anode HF by-pass capacitor.

Output.—C7 feeds signal to grid V4, pentode output. R9 is grid resistor and negative bias for grid, which is developed across R10, in the HT negative return to chassis, is fed in at bottom of R9. Screen voltage V4 is obtained direct from HT line.

L11, primary of OPI, the output matching transformer, is in the anode circuit of V4. C9 provides a degree of fixed tone connection. C10 is HT bypass capacitor. L12, secondary of OPI, feeds the signal to a 6½-in. permanent magnet speaker L13.

High Tension, approximately 82.5V, and grid bias 7.5V, are obtained from a 90V Batrymax B103 battery. S3 is HT on/off switch.

Low tension of 1.5V is obtained from the same battery. S4 is the on/off switch and is connected in the LT+ lead.

The HT and LT switches, S3 and S4, are ganged to the wave change switches S1 and S2.

Chassis Removal.—Remove the three control knobs, back of cabinet and battery.

Remove four wood screws holding chassis to wooden slats on sides of cabinet. (These screws are adjacent to the four frame aerial brackets.)

By holding the output transformer clamping strip the chassis may now be withdrawn. The bottom of the frame aerial must leave the cabinet first.

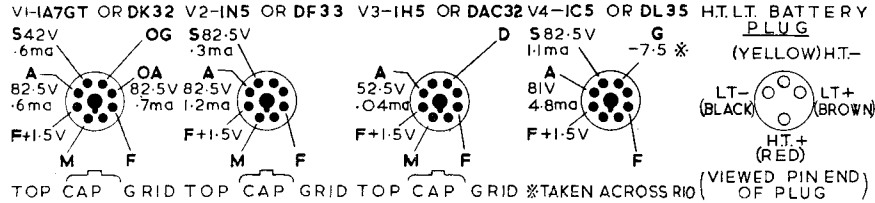

CHASSIS LAY-OUT DIAGRAMS
OVERLEAF

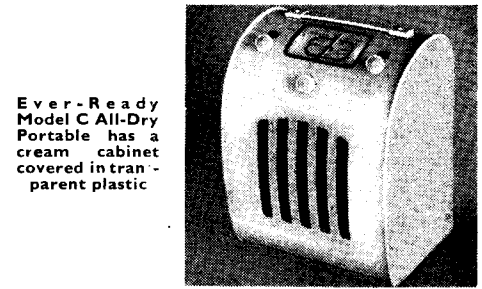
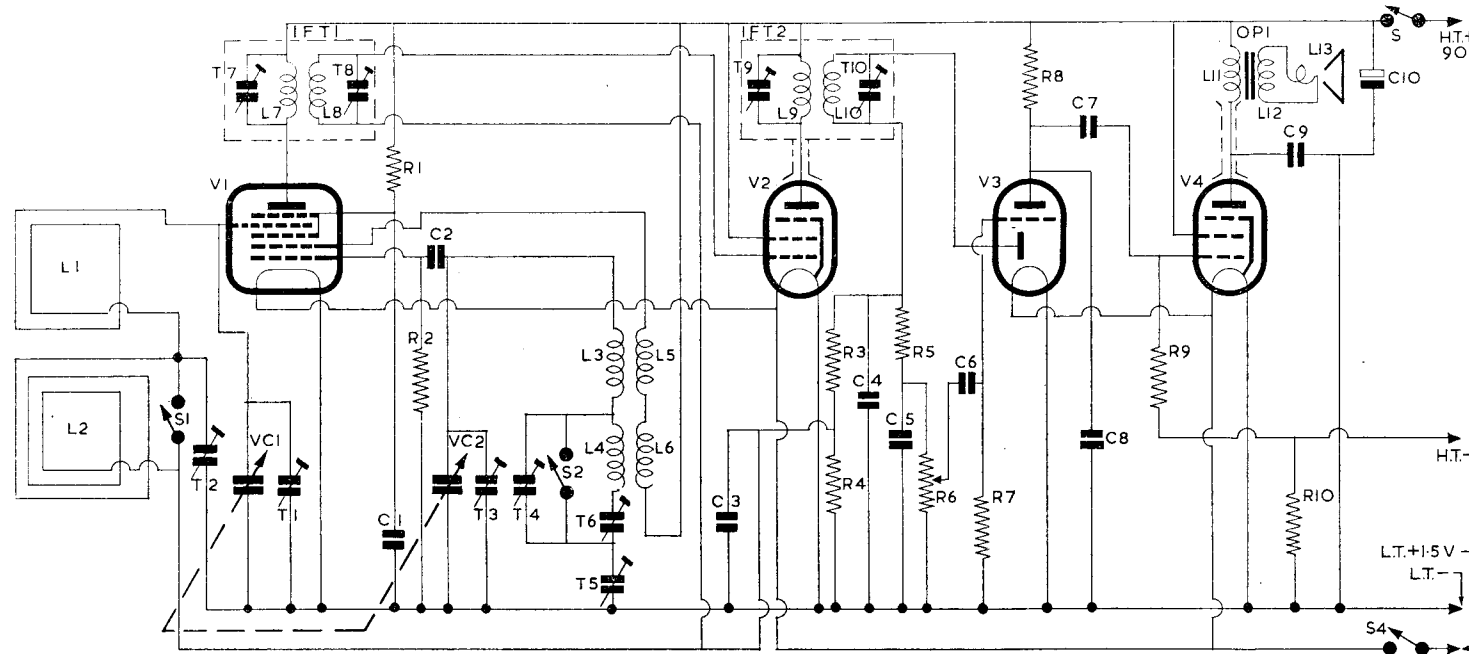

Ever-Ready Model C All-Dry Portable has a cream cabinet covered in transparent plastic

TRIMMING INSTRUCTIONS

Apply signal as stated below	Tune set to	Trim in order stated for max. output
1) 452 Kc to top cap V1 via .01 capacitor (Short circuit VC2)	550 metres	T10, T9, T8 and T7
2) See that pointer registers at max. clockwise	ters with base position (max. x. capacity).	line of scale when
3) 1.410 Mc to frame AE via loop 12 in. from frame	Calibration mark between 200 & 250 metres	T3, T1
4) 600 Kc as above	500 metres	T5 and repeat (3) and (4)
5) 176.5 Kc as above	1700 metres	T6
6) 300 Kc as above	1000 metres	T4, T2 and repeat (5) and (6)

RESISTORS		CAPACITORS	
R	Ohms	C	Mfd's
1	68K	1	.01 Tubular 1000V
2	220K	2	100pF Mica
3	10M	3	.05 Tubular 500V
4	4.7M	4	50pF Mica
5	100K	5	50pF Mica
6	500K Potr.	6	.001 Tubular 1000V
7	10M	7	.005 Tubular 1000V
8	1M	8	100pF Mica
9	2.2M	9	.001 Tubular 1000V
10	820	10	8 Electrolytic 150V

INDUCTORS

L	Ohms
1	1.4
2	21
3	2
4	5.5
5	11
6	together
7	25
8	26
9	25
10	25
11	640
12	.3
13	.3

WAVECHANGE ON/OFF BATTERY H.T.+

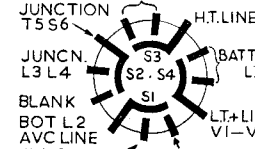

LEFT: Diagram of Wavechange Switch Connections

EVER-READY MODEL C—Chassis Layouts

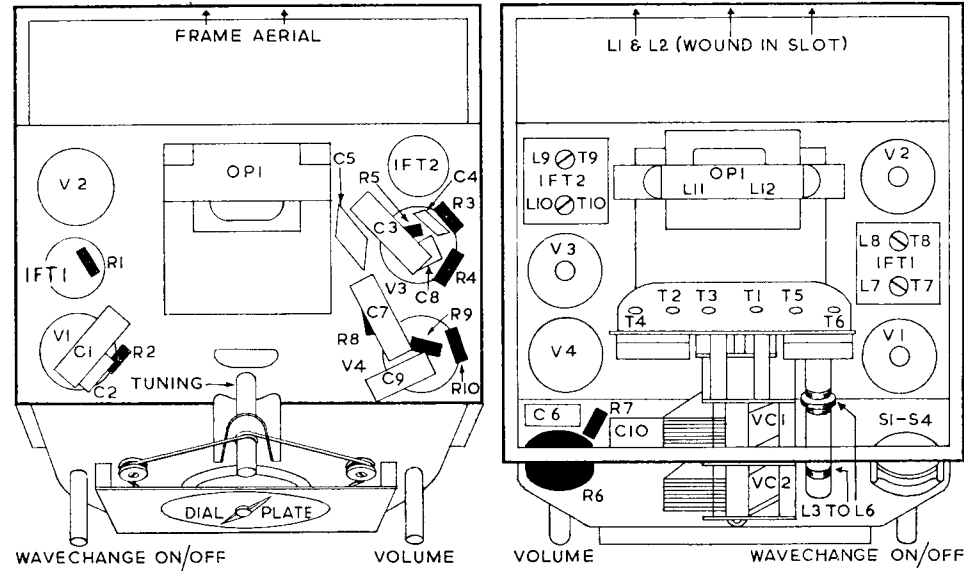

Tools for Repairing Electric Clocks

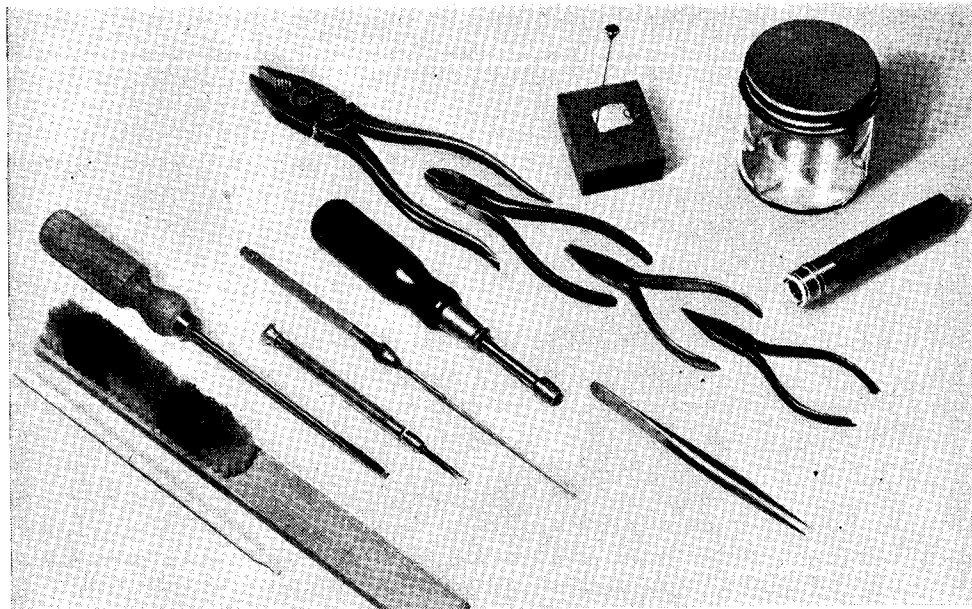

Your minimum clock repair kit. Left to right are, pegwood ; clock or typewriter brush ; clock screwdriver ; watch-maker's screwdriver ; reamer ; 6 BA box spanner and tweezers ; large pliers, cutters and two pairs of small pliers ; oil pot with dipper pin ; jar for cleaning fluid ; pin spanner (for dial nuts)

CALLING RADIO SERVICE DEPOTS!
ELECTROLYTIC CONDENSERS

4 MFD 500 volts working Condensers, block type with flexible leads.	27/- per doz.
8 MFD 150 volts working small type Condensers in insulated cases.	16/- per doz.
8 MFD 150 volts working in metal cans with one hole 2BA fixing, midget size.	18/- per doz.
8 MFD 200 volts working tubular Condensers with wire ends.	24/- per doz.
8 MFD 250 volts working metal cans, single hole 2BA fixing midget size.	27/- per doz.
8 MFD 350 volts working mico-packs, metal can type with tag ends.	33/- per doz.
8 MFD 500 volts working midget cardboard tubulars with wire ends.	36/- per doz.
8 MFD 450/500 volts working, standard size.	32/- per doz.
8 MFD x 4 MFD at 375 volts working, metal can type 3" x 1 3/8" diameter.	45/- per doz.
8 MFD x 8 MFD 450/500 volts working in aluminium cans.	52/- per doz.
8 MFD x 16 MFD 350 volts working metal can type.	66/- per doz.
8 MFD x 16 MFD 500 volts working block type (small quantity only)	72/- per doz.
25 MFD x 25 MFD 200 volts working cardboard block type with flexible leads.	60/- per doz.
10 MFD x 10 MFD 350 volts working plus 20 MFD volt working in one metal can.	60/- per doz.
32 MFD 450/500 volts working in aluminium cans.	48/- per doz.
16 MFD x 32 MFD 275 volts working. Ideal for AC/DC replacements.	84/- per doz.
Fixing Clips for 25 MFD x 25 MFD Condensers as above.	3/- per doz.
Fixing Clips for circular and tubular Condensers.	4/- per doz.

The above is a copy of one of the pages of our August Bulletin. All types of spares supplied. Valves a speciality. ARE YOU ON OUR MAILING LIST? Write for details to:-

V. E. S.

42-46, Windmill Hill, Ruislip, Middlesex.

STURDY FOR REWINDS

For all-round satisfaction, send your rewinds to Sturdy. First-class work, returned in the shortest possible time, and fully guaranteed. For the trade only.

STURDY ELECTRIC CO., LTD.
DIPTON, NEWCASTLE-ON-TYNE
Phone: DIPTON 221. Lists on application.

Don't Buy an OSCILLOSCOPE or WOBBULATOR

before investigating THE ERSKINE MODEL IB

Time Base - 3c/s to 400 Kc/s
Dimensions - 10" x 7 1/2" x 5 1/2"

Write for Specifications -
Delivery October

ERSKINE LABORATORIES LTD.
SCALBY • SCARBOROUGH • YORKS.