

BUSH PB61 SUG61

Four-valve, plus rectifier, three waveband superhet with automatic tuning by pre-set circuits, and in table and console forms. Suitable for 200-250 v., 50-100 cycle A.C. supplies. Made by Bush Radio, Ltd., Power Road, Chiswick, London, W.4.

Circuit.—Transformer coils couple the aerial to V1. Push-button switches select the waveband or connect pre-set capacities across the coils for automatic tuning. The oscillator section of V1, which is the frequency-changer, has separate reaction windings coupled back to the tuned grid circuits. Permeability coils are switched in for automatic tuning.

The I.F. transformers are also permeability tuned. They link up V2, the I.F. amplifier, and V3, the double-diode-triode.

Fed from the primary of I.F.T.2, so that control works over a wider band than that actually occupied by the signal, the A.V.C. diode develops a voltage across R14, and this is fed back to V1 and V2.

The signal demodulation diode is connected in a straightforward manner. Pick-up terminals are provided across the volume control.

The triode section of V3 is resistance-capacity coupled to V4, the output pentode. This has a four-pin plug and socket which connects a parallel tone control and the mains switch, and a second four-pin plug and socket for the speaker field and voice coil connections.

V5 is a full-wave rectifier in a perfectly conventional arrangement.

WAVEBANDS.—16.5-51, 198-565, 850-2,000 metres. Provision for high-impedance pick-up and 2.5 ohm extension speaker. Mains consumption, 60 watts.

GANGING

I.F. CIRCUITS.—Tune to 300 m., volume maximum, tone to low. Connect damping circuit, consisting of 30,000 ohm resistor and .05 mfd. condenser in series, across V2 grid and chassis. Inject 465 kes. between V2 grid and chassis. Adjust L20 for maximum.

Connect damping between V3 signal diode and chassis. Adjust L19 for maximum.

Connect oscillator to V1 grid and damping between V1 hexode anode and chassis. Adjust L18.

Connect damping between V2 grid and chassis. Adjust L17.

Re-check all these adjustments with oscillator, still injecting to V1 grid.

S.W. BAND.—Inject 16.67 mcs. to sensitive aerial socket. Tune to 18 m. Adjust T9 and T2. Check calibration at 50 m.

M.W. BAND.—Tune to 300 m., inject 1,000 kc. and adjust T8 and T1. Check calibration at 500 m.

L.W. BAND.—Tune to 1,500 m., inject 200 kc., and adjust T10 (red) and T3. Check calibration at 1,900 m.

NOTE.—Adjustments to the M. and L.W. aerial trimmers affect the setting of the aerial pre-set condensers. Adjustment of the L.W. oscillator trimmer T10, affects the settings of L13 to L16.

PUSH-BUTTONS

Make adjustment with aerial and earth connected and receiver warm. Press button, adjust oscillator coil core (above button) until required station is heard at its loudest. Turn clockwise to increase wavelength.

Then adjust aerial trimmer (below button) for maximum. Turn clockwise for increase of wavelength.

Repeat both adjustments and check programme against station as received manually.

Button	Wavelength
1	1,100-2,000
2	1,100-2,000
3	325-550
4	200-350

Auto tuning by pre-set circuits is provided in this set. The trimmers are above and below their respective push-buttons as shown on the right.

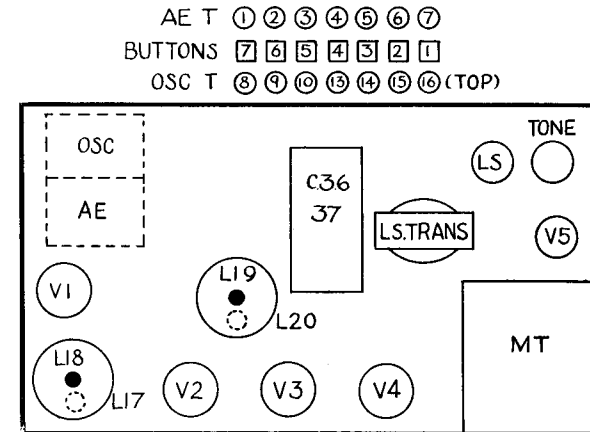

WINDINGS

L.	Ohms.	L.	Ohms.
1	25 .. .5	12	2.3
2	8 .. .1	13,14	2
3	4, 9 .. .05	15-20	4
5	30	21	2.6
6	14	22	2
7	1.5	23	2,000
10	29 .. .1	24	700
11	2.7	26	38
		27	2x500

VALVE READINGS

V.	Type.	Electrode.	Volts.	Ma.
1	TH4B	Anode	265	3
		Screen	75	6
		Osc. anode	75	4.5
2	VP4B	Cathode	1.5	13.5
		Anode	210	6
		Screen	120	2.5
3	TDD4	Cathode	—	8.5
		Anode	100	2.5
		Screen	2.5	2.5
4	Pen A4	Anode	245	27.5
		Screen	265	5
		Cathode	6.5	32.5
5	DW4/350	Anodes	345 A.C.	—
		Cathode	375	57
		Pilot lamps, 6.2 volt .3 amp.		

CONDENSERS

C.	Mfds.	C.	Mfds.
1	50 mmfds.	19	316 mmfds.
1A	50	20	.05
2	800	21	.05
3	5	22	.05
4	5	23	.05
5	30	24	150 mmfds.
6	.5	25	160
7	.05	26	50
8	150 mmfds.	27	100
9	150	28	100
10	30	29	.005
11	10	30	2
12	556	31	50
13	50	32	.03
14	15	33	50
15	316	34	.03
16	130	35	.003
17	340	36	16
18	316	37	8

RESISTANCES

R.	Ohms.	R.	Ohms.
1	1 meg.	10	100,000
2	100	11	10,000
3	30,000	12	50,000
3A	50	13	1,000
4	20,000	14	1 meg.
5	50,000	15	.5
6	10,000	16	200
7	2 meg.	17	100,000
8	.25 meg.	VR1	500,000
9	.5 meg.	VR2	50,000

